

**STINSON BEACH COUNTY WATER DISTRICT  
TITLE IV  
ONSITE WASTEWATER MANAGEMENT CODE**

Adopted on March 20, 2021 - Ordinance No. 2021-01

*“The purpose of this code is to implement the provisions of Article 10, Chapter 1, Part 5, Division 12 of the “Water Code of the State of California” (Section 31145 et seq.) and more specifically to establish regulations to control and enhance the quality of the ground and surface waters of the District by regulating, prohibiting, or controlling the discharge of pollutants, waste, or any other materials into the ground or surface waters or the contiguous water bodies of the District.”*

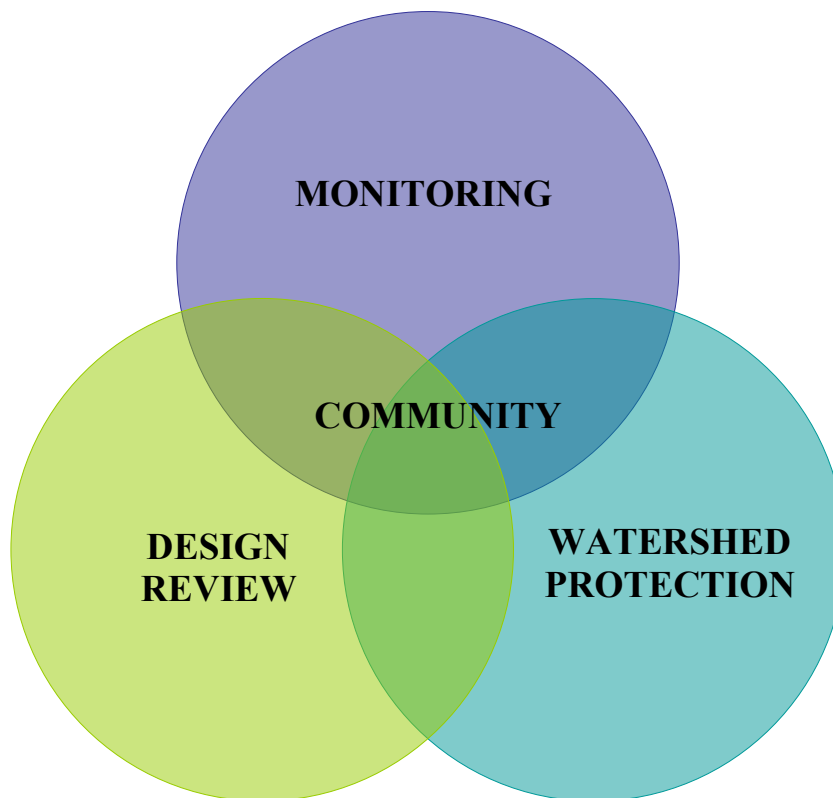

# TABLE OF CONTENTS

## **CHAPTERS**

Chapter 4.01: ADMINISTRATIVE PROVISIONS .....	1
Chapter 4.03: DEFINITIONS .....	4
Chapter 4.05: ENFORCEMENT .....	10
Chapter 4.07: PERMITS.....	17
Chapter 4.12: LAND DIVISION STANDARDS .....	26
Chapter 4.13: VARIANCES TO DESIGN STANDARDS .....	28
Chapter 4.15: DESIGN: STANDARD SYSTEMS .....	31
Chapter 4.19: DESIGN: ALTERNATIVE WASTEWATER SYSTEMS .....	49
Chapter 4.23: DESIGN: HOLDING TANKS AND GRAYWATER SYSTEMS .....	53

## Chapter 4.01: ADMINISTRATIVE PROVISIONS

### **Sections:**

4.01.010	Purpose
4.01.100	Title, Citation, and Reference
4.01.200	Scope
4.01.210	Application to All Current and Future Dischargers
4.01.230	Disposal of Waste
4.01.280	Separate System Required for Each Parcel
4.01.290	Failure to Obtain Required Permit
4.01.310	Repair or Replacement
4.01.410	Alterations and Additions Amounting to New Construction
4.01.430	Alterations & Additions Not Amounting to New Construction
4.01.440	Application for Exemption
4.01.910	Other Requirements
4.01.920	Violation a Misdemeanor
4.01.930	Annual Review and Amendment
4.01.990	Severability

### **4.01.010 Purpose**

The purpose of this code is to implement the provisions of Article 10, Chapter 1, Part 5, Division 12 of the "*Water Code of the State of California*" (Section 31145 et seq.) and more specifically to establish regulations to control and enhance the quality of the ground and surface waters of the District by regulating, prohibiting, or controlling the discharge of pollutants, waste, or any other materials into the ground or surface waters or the contiguous water bodies of the District.

### **4.01.100 Title, Citation, and Reference**

These regulations shall be known as the "Onsite Wastewater Management Code of the Stinson Beach County Water District," may be cited as "Wastewater Code", and will be referred to herein as "this code."

### **4.01.200 Scope**

The provisions of this code shall apply to all discharge and potential discharge of waste or wastewater into soils and waters located within the District. It is the intent of the District to prevent the contamination, pollution, or otherwise rendering unfit for beneficial use, of ground or surface waters.

### **4.01.210 Application to All Current and Future Dischargers**

The provisions of this code shall apply to all persons and properties from which waste or wastewater may be discharged.

### **4.01.230 Disposal of Waste**

No person shall place, deposit, or permit to be deposited upon, within or under, public or private property within the District in a manner not in conformance with all federal, state, and county laws, ordinances, and regulations or in an unsanitary manner, any human or animal excrement, garbage or offal, or other waste or wastewater which may degrade the quality of ground or surface waters.

**4.01.280 Separate Wastewater Treatment System Required for Each Parcel**

No wastewater treatment system shall be constructed, repaired, or replaced to serve more than one parcel. No wastewater treatment system shall be constructed on a separate parcel from the building served unless the parcels are merged or the wastewater treatment system is located within an access and utility easement granted in perpetuity for operation, maintenance, or repair of the wastewater treatment system.

**4.01.290 Failure to Obtain Required Permit**

Any person who commences construction, maintenance, repair, or replacement of a septic system without first obtaining a required permit may be subject to a penalty as prescribed by the General Manager in accordance with Section 4.05.410.

**4.01.310 Repair or Replacement**

Non-maintenance septic system repairs or replacements shall be permitted by the District where the General Manager finds that every element, component, or part of said repair or replacement meets or exceeds the established design standards, set forth in this code and the septic system shall be repaired and/or replaced in conformance with the design standards in effect at the date of the application of repair or replacement.

**4.01.410 Alterations and Additions Amounting to New Construction**

Whenever any person makes application to the County of Marin for a building permit for the purpose of making any alterations to, or enlargements to, a structure, or makes application for the building of a new structure which meets the definition of new construction (as defined in Section 4.03.252) said applicant shall demonstrate that all of the existing septic system components meet the requirements set forth in this code.

**4.01.430 Alterations and Additions Not Amounting to New Construction**

Whenever any person modifies or incorporates an addition to an existing structure, or alters the original structure in a manner that does not constitute new construction (as defined in Section 4.03.252), that person shall, prior to the issuance of a permit and commencement of construction:

1. Be in possession of a valid wastewater discharge permit; and
2. Have had a system inspection conducted within the previous six months; and
3. If the footprint of the building or structure is to be altered or enlarged, or if a new structure is to be added, demonstrate that sufficient space exists on the lot to construct a wastewater treatment system which complies with this code.

**4.01.440 Application for Exemption**

To obtain an exemption to Section 4.01.410, the owner of the property on which the alteration or enlargement is proposed shall file an application on a District form and shall pay the prescribed application fee. Every such application shall provide:

1. A site plan that delineates the location of the septic system, all structures located on the property, nearby geologic features (such as cut banks), watercourses, wetlands, water wells, a dedicated reserve area, and property slope; and
2. Proof of a special inspection of the system within the previous 45 days with a statement of determination made by District Staff that the system is in good working condition and that it does not pose a threat to public health; and
3. Copies of all documents and plans submitted to the County of Marin for such

- alteration or enlargement; and
4. Any other item determined to be necessary by the District Engineer and/or the General Manager to adequately evaluate the system.

**4.01.910 Other Requirements**

Nothing within this code shall be construed to reduce or impede or otherwise interfere with any additional requirement that may be imposed by any law, ordinance, rule, or regulation of a legally constituted authority having jurisdiction over such matters.

**4.01.920 Violation a Misdemeanor**

Any violation of this code is a misdemeanor punishable by a fine not to exceed one thousand dollars (\$1,000.00) or imprisonment not to exceed 60 days or both. Each day of such a violation shall constitute a separate offense.

**4.01.930 Annual Review and Amendment**

This code shall be reviewed annually by the District Wastewater Committee for applicable changes in State Health requirements and/or Regional Water Quality Control Board regulations. The Board of Directors shall complete a full review of this code at no less than three-year intervals. This code may not be amended except by ordinance of the Board of Directors of the Stinson Beach County Water District with the written approval of the Executive Officer of the Regional Water Quality Control Board of California.

**4.01.990 Severability**

If any section, subsection, sentence, clause, or phrase of this code is, for any reason, held to be unconstitutional or unenforceable, such decision shall not affect the validity of the remaining portions of this code. The Board of Directors hereby declares that it would have passed this code, each section, subsection, clause, or phrase thereof, irrespective of the fact that any one or more sections, subsections, sentences, clauses, and phrases be declared unconstitutional.

## Chapter 4.03: DEFINITIONS

### **Sections:**

4.03.010	General
4.03.030	Terms Defined by Federal and State Agencies
4.03.050	Other Sources of Definitions
4.03.090	Common Definition
4.03.202	Alternative System
4.03.205	Change of Use
4.03.207	Chemical Toilet
4.03.212	Cut or Embankment
4.03.215	Designer
4.03.216	Discharge Permit
4.03.217	District Engineer
4.03.220	Downslope Property Line
4.03.224	Dispersal Field
4.03.225	Drip Dispersal
4.03.226	Dual Dispersal Fields
4.03.227	Existing Use
4.03.228	Failed System or Failed Wastewater Treatment System
4.03.229	Failed System Citation
4.03.230	Graywater
4.03.231	Graywater System
4.03.231.1	Grease interceptor or Grease Trap
4.03.232	Groundwater
4.03.237	Habitable Space
4.03.244	Maintenance
4.03.248	M.P.N. - Most Probable Number
4.03.252	New Construction
4.03.258	Non-Treatment Component
4.03.260	Pretreatment Device
4.03.264	Repair or Replacement
4.03.266	Saturated Soil
4.03.268	Setback
4.03.270	Soil Depth
4.03.271	Special Flood Hazard Area
4.03.273	Standard System
4.03.276	Temporary Use
4.03.278	Treatment Component
4.03.280	Unstable Landform
4.03.283	Wastewater
4.03.284	Wastewater Treatment System
4.03.285	Watercourse
4.03.286	Water Bodies
4.03.288	Water System
4.03.292	Well

#### **4.03.010 General**

For the purpose of this code, certain terms, phrases, words and their derivatives shall be construed as specified in this chapter. Words used in the singular include the plural, and the plural the singular. Words used in the masculine gender include the feminine, and the feminine the masculine.

#### **4.03.030 Terms Defined by Federal and State Agencies**

Terms which are not specifically defined in this code shall be as defined in the "*Minimum Guidelines for the Control of Individual Wastewater Treatment & Disposal Systems of the California Regional Water Quality Control Board, San Francisco Bay Region*" (hereinafter referred to as Minimum Guidelines), Appendix A. Terms not defined in this code or in said Appendix A shall be as defined in the Glossary of the most recent edition of the "*Design Manual: Onsite Wastewater Treatment and Disposal Systems*", (hereinafter referred to as Design Manual) and any subsequent revisions, published by the United States Environmental Protection Agency.

#### **4.03.050 Other Sources of Definitions**

Terms which are not defined in this code or the sources listed in 4.03.030, but which are defined in the most recently published version of the "*Uniform Plumbing Code*" (hereinafter referred to as Uniform Plumbing Code), as published by the International Association of Plumbing and Mechanical Officials, shall be construed as specified in that code. Additionally, terms which are not defined in this code or other sources prescribed above, but which are defined in the most recently published version of the "*Uniform Building Code*" as published by the International Conference of Building Officials, shall be construed as specified in that code.

#### **4.03.090 Common Definition**

Terms herein for which a definition is not otherwise prescribed either in this code or in other sources referred to herein shall have their ordinarily accepted meaning within the context in which they are used. "*Merriam Webster's Third New International Dictionary of the English Language, Unabridged*", copyright 2002 or a successive publication shall be considered as providing ordinarily accepted meanings.

#### **4.03.202 Alternative System**

Alternative system shall mean a wastewater treatment system other than a standard septic system.

#### **4.03.205 Change of Use**

Change of use shall mean that either the quality and/or quantity of wastewater disposed in a wastewater treatment system has changed such that the existing system may be inadequate for the use.

#### **4.03.207 Chemical Toilet**

A chemical toilet is a temporary toilet which utilizes chemicals to mask odors.

#### **4.03.212 Cut or Embankment**

A cut or an embankment shall mean all cuts and embankments, whether or not retained by a structure, as defined in the Minimum Guidelines, which cut or embankment is greater than 24 inches (24") in vertical height.

**4.03.215 Designer**

A designer shall mean any person licensed, registered, or otherwise authorized by the State of California to design onsite wastewater systems.

**4.03.216 Discharge Permit**

Discharge permit shall mean a recorded document that authorizes operation of an onsite wastewater treatment system in accordance with this code.

**4.03.217 District Engineer**

The District engineer shall mean any engineer appointed pursuant to 4.05.020 whom the General Manager has deputized to act on his behalf to implement this code.

**4.03.220 Downslope Property Line**

Downslope property line shall mean a property line of the subject property where the ground on the adjacent property slopes downward from that property line.

**4.03.224 Dispersal Field**

Dispersal field shall mean a system of trenches or beds that distribute treated sewage effluent for absorption into the soil. "Soil absorption system" as used in the Minimum Guidelines, "disposal field" as used in the Uniform Plumbing Code, and "leach field" as commonly used shall be considered synonymous with dispersal field.

**4.03.225 Drip Dispersal**

Drip dispersal shall mean dispersal of high quality effluent for subsurface landscaping utilizing a non-clogging drip tube and non-clogging emitters.

**4.03.226 Dual Dispersal Fields**

Dual dispersal fields shall mean a wastewater treatment system that includes two complete dispersal fields connected by an accessible diversion valve and intended for alternating use.

**4.03.227 Existing Use**

Existing use shall mean that the quality and quantity of wastewater disposed in a wastewater treatment system is unchanged.

**4.03.228 Failed System or Failed Wastewater Treatment System**

Failed system and failed wastewater treatment system shall mean a wastewater treatment system which is discharging in violation of this code, or a wastewater treatment system whose components do not meet the specifications of this code.

**4.03.229 Failed System Citation**

Failed System Citation is the District's primary tool for enforcement. A Failed System Citation is issued after a Discharge Permit has been revoked pursuant to Section 4.07.740, and the citation is recorded at the office of the Marin County Recorder.

**4.03.230 Graywater**

Graywater is untreated water which has not come into contact with toilet waste. Graywater includes used water from hot tubs, bathtubs, showers, bathroom wash basins, clothes washing machines and laundry tubs or an equivalent discharge. It does not include waste water from kitchen sinks, photo lab sinks, dishwashers or laundry water from soiled diapers.



**4.03.231 Graywater System**

Any onsite wastewater system design which conforms to 2013 California Plumbing Code (CPC), Chapter 16, Non-potable Water Reuse Systems shall be designated a graywater system.

**4.03.231.1 Grease Interceptor or Grease Trap**

An external, in-ground, watertight receptacle/chamber, designed and constructed to intercept fats, oils, and grease upstream of the septic tank and/or any supplementary treatment tank.

**4.03.232 Groundwater**

Groundwater shall mean any subsurface body of water.

**4.03.237 Habitable Space**

Habitable space shall mean space within a structure that is designed or useable for living, sleeping, eating, or cooking. Bathrooms, toilet compartments, closet, hall, storage, or utility space and similar areas are not considered habitable space, but will be included when calculating the total floor area under Section 4.15.621. Habitable space shall be measured from the interior walls in a residence or detached building.

Most space within a structure shall be deemed habitable space. Non-habitable space, however, will include rooms or enclosed spaces which do not have windows, are not connected to central heating or cooling, and are not designed and intended for human occupancy, including, but not necessarily limited to the following:

- A. Garages used for vehicular parking or storage
- B. Unfinished basements
- C. Mechanical equipment rooms
- D. Unimproved space that does not meet the minimum height standard for habitable space according to the California Building Code (CBC)
- E. Stairwells, other than the ground floor landing for each stairwell (i.e., each stairwell only counted once)
- F. Non-habitable accessory structures

**4.03.244 Maintenance**

Maintenance of a wastewater treatment system shall mean clearing of stoppages in pipes in nontreatment components; repairing or replacing non-treatment components of a wastewater system; pumping liquid and solids from, or otherwise cleaning septic tanks and grease traps; cleaning sand filters; and cleaning pressure distribution system pumps and piping.

**4.03.248 M.P.N. - Most Probable Number**

M.P.N. (most probable number) is an estimate of the actual number of colony-forming units based on established probability formulae. For further explanation, see "*Standard Methods for the Examination of Water and Wastewater*".

**4.03.252 New Construction**

New construction shall mean the construction of a new building or building addition with habitable space. Further, the construction of any new structure within a setback from a component of a wastewater system required at the time the system was installed shall be deemed to be new construction.

#### **4.03.258 Non-Treatment Component**

Non-treatment component shall mean a component of an onsite wastewater treatment system that is not a treatment component. This includes, but is not limited to, risers, septic tank lids, tight lines, inlet T's, outlet T's, diversion valves, and non-perforated pipe.

#### **4.03.260 Pretreatment Device**

Pretreatment Device shall mean a treatment component, such as a sand filter, recirculating textile filter, or aerobic treatment unit which is designed to reduce contaminants in wastewater effluent prior to treatment and dispersal in the leach field.

#### **4.03.264 Repair or Replacement**

Repair or replacement shall mean the alteration, changing, repairing, or replacing of any part, component, or element of a wastewater treatment system, or soils surrounding said parts, excepting such activities which are carried out in conjunction with or resulting from new construction.

#### **4.03.266 Saturated Soil**

Saturated soil shall mean soil that has reached its moisture holding or "field" capacity.

#### **4.03.268 Setback**

Setback shall mean the horizontal distance as measured between the nearest points or edges of specified structures, features, wastewater treatment system components, and/or property lines. If the horizontal distance between a wastewater system component and a structure exceeds another distance between the component and the structure as measured in a straight line, "minimum setback" shall mean a straight-line distance.

#### **4.03.270 Soil Depth**

Soil depth shall mean the combined thickness of soil layers which are suitable for effluent soil absorption systems. Soil depth is measured vertically from the surface to bedrock, hardpan, or an impermeable soil layer.

#### **4.03.271 Special Flood Hazard Area**

Special Flood Hazard Area includes Zones A, AE, AH, AO, AR, A99, V, and VE as shown in the most current FEMA Flood maps for the Stinson Beach area.

#### **4.03.273 Standard System**

Standard system shall mean a wastewater treatment system that includes as its components for purposes of treatment:

1. a septic tank; and
2. a leach field (dispersal field)

A standard septic system may have other non-treatment components such as a distribution pump, tight line, etc.

#### **4.03.276 Temporary Use**

Temporary use shall mean a use, which either is active during three or fewer calendar months within any calendar year or is active for less than six consecutive months.

#### **4.03.278 Treatment Component**

Treatment component shall mean the elements or parts of a wastewater treatment system which are intended or designed to reduce the contaminants in wastewater prior to its combining

with groundwater.

**4.03.280 Unstable Landform**

Unstable landform shall mean an area that shows evidence of mass downslope movement.

**4.03.283 Wastewater**

Any and all waste, substance, liquid or solid, which contains or may be contaminated by human waste or other substances that may be injurious or dangerous to health either directly or indirectly.

**4.03.284 Wastewater Treatment System**

Wastewater treatment system, dispersal system, or wastewater system shall mean any devices, parts, elements, structures, and/or components, located between the building and the point of discharge into soil.

**4.03.285 Watercourse**

Watercourse shall mean a definite open channel with bed and banks within which natural water flows either perennially, ephemeral, or intermittently including overflow channels contiguous to the main channel. A watercourse shall include both natural and manmade channels.

**4.03.286 Water Bodies**

Water bodies shall mean all of the Bolinas Lagoon, the Seadrift Lagoon, and the Pacific Ocean. Water bodies shall also include wetlands, seasonal wetlands as defined by the U.S. Army Corps of Engineers, or other bodies of water such as ponds or lakes.

**4.03.288 Water System**

Water system shall mean any water source, water treatment unit, water storage, or water distribution system, or any combination thereof, other than any such water system owned by the District or other public agency.

**4.03.292 Well**

Well shall mean any excavation that is drilled, cored, bored, washed, driven, dug, jetted, or otherwise constructed which excavation is intended to discover, locate, extract, or artificially recharge groundwater.

## Chapter 4.05: ENFORCEMENT

### **Sections:**

- 4.05.010 Enforcement and Interpretation by General Manager
- 4.05.020 Appointment of District Engineer and Other Employees
- 4.05.025 Public Officers
- 4.05.030 Right of Entry
- 4.05.040 Stop Orders
- 4.05.050 Order to Discontinue Use, Discontinue Discharge, and/or Vacate
- 4.05.060 Appeal of Determination or Order of General Manager
- 4.05.065 Limitation of Authority of the Board
- 4.05.070 Effect of Failure to Appeal
- 4.05.080 Scope of Hearing on Appeal
- 4.05.090 Staying of Orders
- 4.05.100 Decision of Board Final
- 4.05.110 Means of Enforcement
- 4.05.210 Limitation of Liability
- 4.05.310 Tampering Prohibited
- 4.05.410 Application Fees, Permit Fees and Charges
- 4.05.420 Discharge Permit Fees - Unified Billing
- 4.05.430 Special Inspection Fees
- 4.05.440 Violation a Nuisance
- 4.05.450 Other Nuisances
- 4.05.460 Notices
- 4.05.470 Summary Abatement in Case of Emergency
- 4.05.480 Effect of Failure to Abate
- 4.05.490 Hearing - Resolution of Findings
- 4.05.500 Abatement of Nuisance by District
- 4.05.510 Owner Request for District to Abate the Nuisance

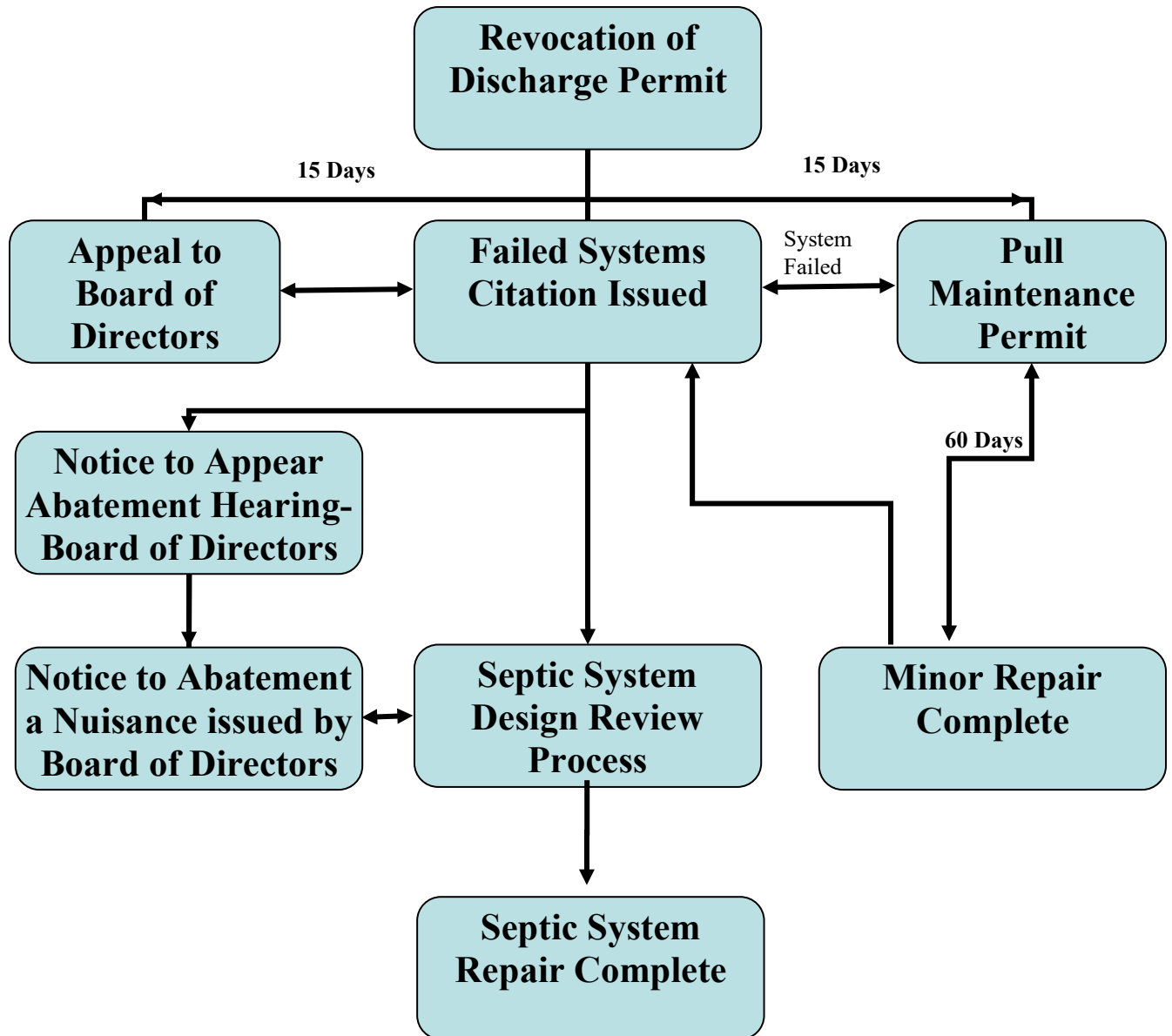

**WASTEWATER SYSTEM FAILURE PROCESS**

**4.05.010 Enforcement and Interpretation by General Manager**

The General Manager of the Stinson Beach County Water District is hereby authorized and directed to enforce all the provisions of this code. The General Manager shall have the power to render interpretations of this code and enforce rules and supplemental regulations in order to clarify the application of its provisions. Other officers of the District shall assist and cooperate with the General Manager in order to implement this code.

**4.05.020 Appointment of District Engineer and Other Employees**

The General Manager may appoint a District Engineer and other employees to implement this code. The General Manager may deputize such appointees to act on his/her behalf to implement this code. Such deputized appointees hereinafter may be referred to as "deputy."

**4.05.025 Public Officers**

For purposes of enforcement of this code, the General Manager and appointees deputized pursuant to Section 4.05.020 herein above shall be public officers as provided in 836.5 of the *Penal Code of the State of California*.

**4.05.030 Right of Entry**

When it is necessary to make an inspection to enforce the provisions of this code, or when the General Manager or deputy has reasonable cause to believe that there exists upon a parcel a condition which is contrary to, or in violation of, this code, the General Manager or deputy may enter upon the parcel and/or building(s) thereon to perform the duties imposed by this code; provided however, that if such parcel or building is occupied, credentials shall be presented to the occupant and entry requested. If such parcel or building is unoccupied, a reasonable effort shall be made to locate the owner or other person having charge or control of the parcel or building in order to request entry. Denial of entry constitutes a violation of this code and an inspection warrant may be obtained as provided by law or abatement proceedings may commence.

**4.05.040 Stop Orders**

Whenever any maintenance, repair, replacement, or new construction work is being done contrary to the provisions of this code or other pertinent laws or ordinances implemented through the enforcement of this code, the General Manager may order the work stopped by notice in writing served on any such person(s) engaged in doing or causing such work to be done, and any such person(s) shall forthwith stop such work until authorized by the General Manager to proceed with the work.

**4.05.050 Order to Discontinue Use, Discontinue Discharge, and/or Vacate**

Whenever any parcel or building regulated by this code is being used contrary to the provisions of this code or is discharging waste in violation of this code, the General Manager may order such use discontinued, such discharge discontinued, and/or the parcel or building or portion thereof vacated by serving a notice on any person causing such use. Such person shall discontinue the use and/or vacate the parcel or building or portion thereof within the time prescribed within the notice.

**4.05.060 Appeal of Determination or Order of General Manager**

Orders, decisions, or determinations made by the General Manager relative to the application and interpretation of this code may be appealed within 15 calendar days from the date of service or notification of said order, decision, or determination. Said appeal shall be filed with the District and prescribed fees shall be paid. The filed appeal shall be essentially in the following form:

1. A heading in the words: "Before the Board of Directors of the Stinson Beach

- County Water District";
2. A caption reading: "Appeal of [give the names of all appellants participating in the appeal]";
  3. A brief statement setting forth the legal interest of each of the appellants in the parcel(s) or building(s) involved;
  4. A brief description of the specific order, decision or determination appealed;
  5. A brief statement in ordinary and concise language of the relief sought and the reasons why it is claimed that the order, decision or determination should be reversed, modified, or otherwise set aside;
  6. A brief statement in ordinary and concise language of any material facts claimed to support the contentions of the appellant;
  7. The signatures of all parties named as appellants and their official mailing addresses;
  8. The verification (by declaration under penalty of perjury) of at least one appellant as to the truth of the matters stated in the appeal.

The appeal shall be placed as public hearing on the agenda of the next regular meeting of the Board of Directors, which occurs 15 calendar days or later following the date of receipt of the appeal. Written notice of the time and place of the hearing shall be mailed to each appellant by certified mail at least seven calendar days prior to the date of the hearing.

#### **4.05.065      Limitation of Authority of the Board**

The Board of Directors when ruling on an appeal may not set aside or modify the application of discharge or design standards as provided in this code, nor may the Board take up any matter more properly considered as a request for a variance pursuant to Chapter 4.13 of this code. Any ruling of the Board of Directors on an appeal may be reviewed and set aside by the Executive Officer of the Regional Water Quality Control Board upon making a finding that the Board of Directors exceeded the limitation specified in this section.

#### **4.05.070      Effect of Failure to Appeal**

Failure of any person to file an appeal in accordance with the provisions of Section 4.05.060 shall constitute a waiver of the right to an administrative hearing and adjudication of the order, decision, or determination of the General Manager provided that said order, decision, or determination has been rendered in writing and said writing is accompanied by a copy of Section 4.05.060.

#### **4.05.080      Scope of Hearing on Appeal**

Only those matters or issues specifically raised by the appellant shall be considered in the hearing of the appeal.

#### **4.05.090      Staying of Orders**

Except for orders issued pursuant to Section 4.05.040 or to Section 4.05.050, any order, decision, or determination of the General Manager shall be stayed during the pendency of an appeal when the appeal has been properly and timely filed.

#### **4.05.100      Decision of Board Final**

A decision of the Board of Directors regarding an appeal shall be final.

#### **4.05.110      Means of Enforcement**

The following shall constitute means of enforcement of orders issued pursuant to Section 4.05.040 or Section 4.05.050:

1. Injunctive relief may be sought in a court of proper jurisdiction pursuant to sections 31145 through 31149 of the “*Water Code of the State of California*”.
2. As provided in section 31147 of the *Water Code*, nuisance abatement proceedings may be initiated pursuant to Chapter 4.05 of this code.
3. As a means of abatement of a nuisance, District water service may be terminated in order to prevent further discharge of wastewater. When the continued discharge may constitute an immediate threat to the health and safety of the public or may cause harm to the riparian environment, said water service may be terminated immediately.

#### **4.05.210      Limitation of Liability**

Article 10, Chapter 1, Part 5, Division 12, of the “*Water Code of the State of California*” (Section 31145 et seq.) imposes upon the District certain duties to protect the quality of the surface waters and ground waters within and passing through the District. The establishment, enforcement, and implementation of this code are among those duties. Notwithstanding any other provision of this code or permit issued hereunder, any person discharging waste pursuant to such a permit shall have the obligation to conform to all related laws and regulations of all state and local agencies and such person shall indemnify the District from any and all damages, penalties, or other expenses imposed on, or required, of the District by such federal, state, or local agency due to such discharge of waste. Further, the District's liability, and the liability of its officers and employees, for acts or omissions pursuant to this code are limited under the provisions of the California Tort Claims Act. Notwithstanding any other provision of this code, the intent of the Board is that all duties imposed by this code upon the District and/or any District officer or employee are discretionary in nature. Any suit brought against any officer or employee of the District because of an act or omission of said officer or employee in the establishment of and enforcement of this code and/or any provision thereof and/or other pertinent laws or regulations implemented through this code shall be defended by the District until final termination of such proceedings, and any judgment resulting therefrom shall be assumed by the District unless it is determined that said act or omission falls within the categories of conduct specified in “*Government Code*” Section 995.2 or any successor statute thereof.

#### **4.05.310      Tampering Prohibited**

In order to carry on technical and other investigations, examinations, or tests of surface water and groundwater within and passing through the District, the District may establish and install equipment, test wells, and other devices on public property and, with the permission of the owner, on private property. No person shall tamper with, remove, or modify such equipment, test wells, and other devices or otherwise interfere with the conduct of such investigations, examinations, or tests.

#### **4.05.410      Application Fees, Permit Fees and Charges**

The Board of Directors, pursuant to Article 10, Chapter 1, Part 5, Division 12, section 31145 et seq. of the “*Water Code of the State of California*” and in a manner prescribed by law may, by resolution, establish and alter fees and charges to receive applications, hold hearings, review plans and specifications, perform inspections, issue permits, and to perform any other service related to maintaining and operating the onsite wastewater management program. Said fees shall be sufficient to offset the cost of conducting the program. No wastewater treatment system shall be constructed, repaired, replaced, maintained, or operated until all such fees have been paid.



#### **4.05.420 Discharge Permit Fees - Unified Billing**

The fee for a discharge permit issued pursuant to Section 4.07.710 may be collected periodically and the District may bill the permittee with the water service billing on a unified bill. Collection, penalties for late payment, and other procedural matters related to billing shall be the same as those provided by the District for water service. Water shall not be sold to any premises where discharge permit fees or other fees and charges established pursuant to Sections 4.05.410 are delinquent.

#### **4.05.430 Special Inspection Fees**

All systems are subject to periodic special inspections as determined by District staff, or requested by the property owner. The prescribed inspection fees for such special inspections are the responsibility of the property owner.

#### **4.05.440 Violation a Nuisance**

Pursuant to the provisions of section 31147 of the "*Water Code of the State of California*", violation of any of the provisions of this code is a nuisance subject to abatement.

#### **4.05.450 Other Nuisances**

The procedures for abatement of a nuisance established in this code may be used to abate any nuisance, which pursuant to law may be abated by the District.

#### **4.05.460 Notices**

Notices regarding abatement of a nuisance shall be sent by certified mail to the property owner(s) at said owner's mailing address as shown on District records. A copy of such notice shall be posted conspicuously upon the property. Failure of the owner (or any other person to whom notice is given) to receive a notice required in this chapter shall not affect the validity of any proceedings conducted pursuant to this code.

#### **4.05.470 Summary Abatement in Case of Emergency**

When the conditions that constitute the nuisance pose an immediate threat to the public peace, health, or safety, or may cause irreparable harm to the environment, the District Board and/or the General Manager may immediately abate the nuisance pursuant to Section 4.05.500.

#### **4.05.480 Effect of Failure to Abate**

Upon making a determination that a nuisance exists upon a parcel within the District, the General Manager shall within thirty days from the date of the Failed System Citation, issue a notice directing the owner or the owner's authorized agent to appear before the Board of Directors at a stated time and place at the next regular Board meeting which falls at least ten days after the date of the issued notice to show cause why the Board should not order the nuisance abated.

#### **4.05.490 Hearing - Resolution of Findings**

At the time fixed in the notice, the Board shall hear the testimony of all competent persons desiring to testify respecting the condition constituting the nuisance. At the conclusion of the hearing, which may be continued, the Board shall by resolution declare its findings. If the Board finds that sufficient evidence exists to support a determination that a nuisance exists, it may include in the resolution a declaration that the nuisance exists and an order directing the owner of the property upon which the nuisance exists to abate the nuisance within a defined time. A copy of the signed Resolution directing abatement of a nuisance shall be forwarded to the property owner within seven days after the hearing.

**4.05.500 Abatement of a Nuisance by District**

If the nuisance has not been abated within the time prescribed, or if the nuisance poses an immediate threat, the Board may, by resolution, order the General Manager (1) to terminate water service to prevent further discharge of wastewater, or (2) to abate the nuisance. The General Manager may submit the estimated cost to abate the nuisance and any other pertinent information to the Board. The General Manager may direct any District employee, contracting agent, or other representative to enter upon the private property in a manner consistent with Section 202c of the Uniform Building Code for purposes of abating the nuisance.

**4.05.510 Owner Request for District to Abate the Nuisance**

At any time following receipt of the notice of abatement hearing regarding a failed onsite wastewater treatment system as provided for in Section 4.05.490, the owner may request the District to abate the nuisance pursuant to the provisions of section 31148 of the "*Water Code of the State of California*". The District and the owner may enter into agreements effecting such abatement.

## Chapter 4.07: PERMITS

### **Sections:**

- 4.07.060 Septic Pumping Permits Required
- 4.07.070 Chemical Toilet Permit
- 4.07.071 Chemical Toilets in Village Green Parks
- 4.07.090 New Construction Permit and Maintenance Permit Requirements
- 4.07.110 Application for a Construction Permit
- 4.07.112 Design Approval Permit Required
- 4.07.114 Discharge Permit Required
- 4.07.115 Valid Discharge Permit
- 4.07.118 Compliance with California Environmental Quality Act
- 4.07.130 Design Review Application
- 4.07.131 Designer's Inspection Schedule
- 4.07.133 Exemption from Design Review Application – Minor System Repair
- 4.07.135 Determination of Complete Design Review Application
- 4.07.215 Determination of Incomplete Design Review Application
- 4.07.220 Approval of Design Review Application and Plans; Issuance of Design Approval Permit
- 4.07.230 Notice to Agencies of Design Approval - New Construction
- 4.07.310 Revocation of Design Approval Permit
- 4.07.410 Retention of Plans
- 4.07.510 Licensed Contractor Required
- 4.07.610 Inspections
- 4.07.620 Certification by Designer
- 4.07.630 Certification of As-built Plans
- 4.07.710 Discharge Permit
- 4.07.720 Periodic Inspection
- 4.07.725 Accessibility for Periodic Inspection
- 4.07.730 Purpose of Periodic Inspection
- 4.07.732 Scope of Periodic Inspection
- 4.07.733 Notification of Completed Inspection
- 4.07.735 Change of Use
- 4.07.740 Revocation of Discharge Permit and Failed System Citation
- 4.07.745 Reissue of Discharge Permit
- 4.07.760 Grading Permit Application
- 4.07.770 Other Permits

**PRE-DESIGN PHASE**

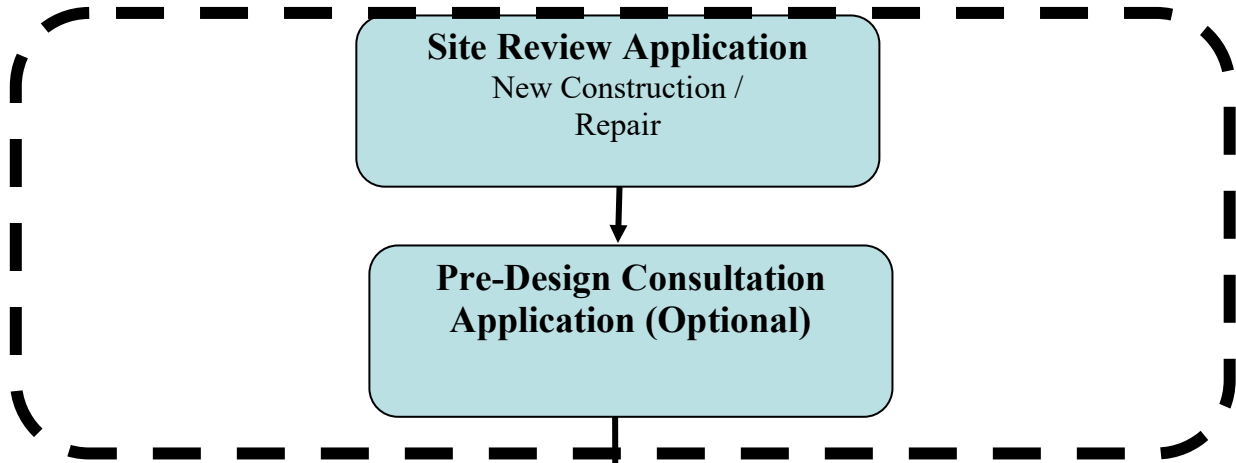

**DESIGN PHASE**

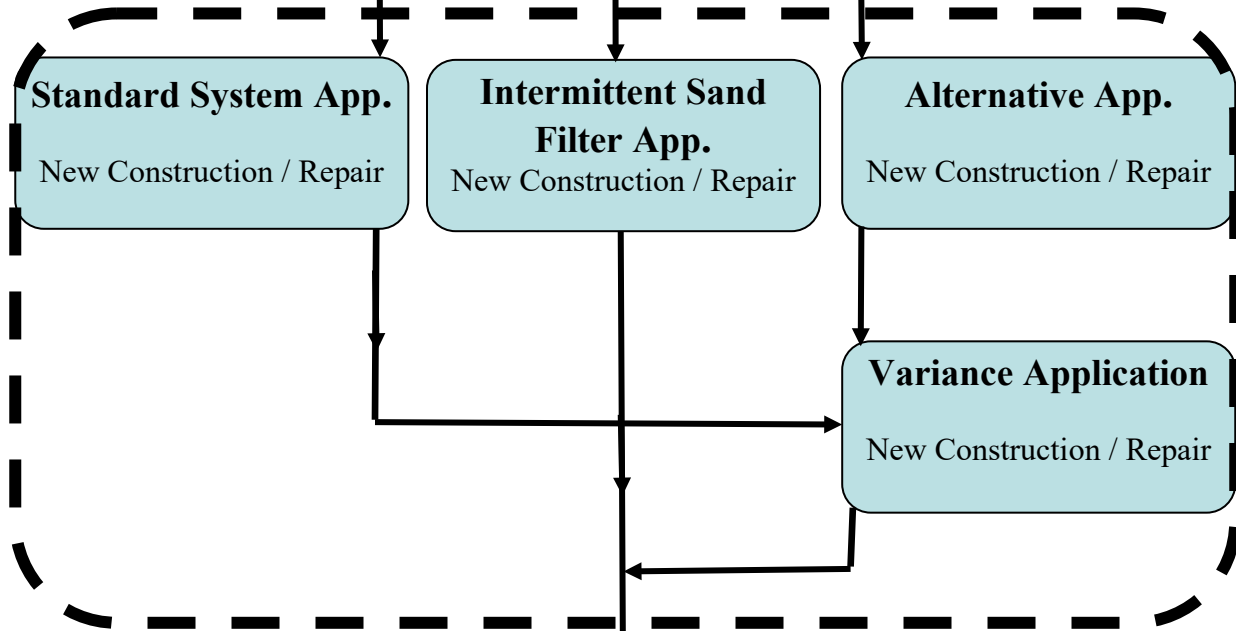

**CONSTRUCTION PHASE**

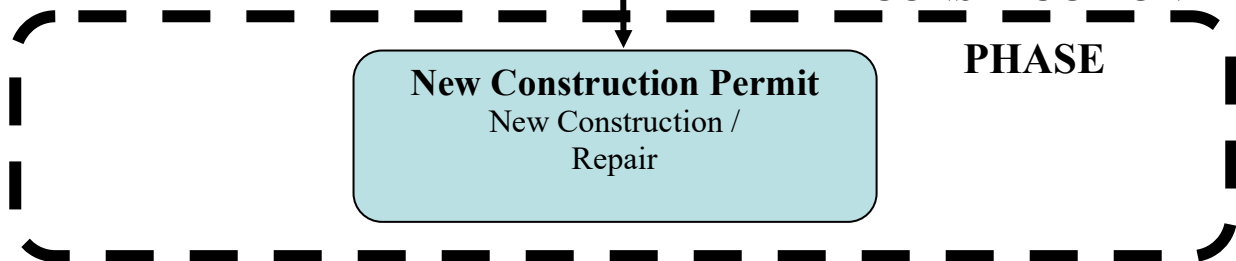

**TYPICAL DESIGN REVIEW PROCESS FOR NEW OR REPAIR WASTEWATER TREATMENT SYSTEM**

#### **4.07.060 Septic Pumping Permits Required**

Septic pumping contractors and/or waste haulers performing any extraction or hauling of septic waste or food waste or grease within the Stinson Beach County Water District boundaries shall be required to make annual application for a Pumping Permit and shall pay the applicable permit fee. All septic pumping contractors shall be licensed by the County of Marin pursuant to 25000 et seq. of the Health and Safety Code and shall submit a copy of the current County permit to the District prior to issuance of the Septic Pumping Permit.

#### **4.07.070 Chemical Toilet Permit**

Except as specifically provided herein, no person shall use a chemical toilet on any parcel within the District. Such devices may be used temporarily in connection with the construction of a building or other structure during the period of such construction or in connection with the repair of a failed wastewater treatment system or upon application to the District for a private special event. Upon filing of a temporary toilet permit application and payment of the prescribed fee, a permit for such a device serving a temporary use may be issued provided that the device will be provided by and pumped by a person licensed by the County of Marin pursuant to 25000 et seq. of the *“Health and Safety Code”*.

#### **4.07.071 Chemical Toilets in Village Green Parks**

Notwithstanding Section 4.07.070 above, chemical toilet(s) may be used in the Village Green Parks. Each device shall be provided and pumped by a person licensed by the County of Marin pursuant to sections 25000 et seq. of the California Health and Safety Code. Such device(s) shall be serviced and pumped twice a week during the period May 1<sup>st</sup> to September 30<sup>th</sup>. The District shall have the discretion to require the non-operation or removal of the device(s) from either or both parks if in the opinion of its General Manager the continued use of such devices will create a health hazard or public nuisance. The Determination of the General Manager may be appealed to the Board of Directors.

#### **4.07.090 New Construction Permit and Maintenance Permit Requirements**

No person shall engage in any of the following activities as specifically defined in this code without having first obtained a permit from the District:

1. New Construction (as defined in Section 4.03.252)
2. Repair or replacement (as defined in Section 4.03.264) of any treatment or dispersal component of the wastewater system
3. Maintenance (as defined in Section 4.03.244) of any treatment or dispersal component of the wastewater system

A construction permit shall be valid for a period of two (2) years. A maintenance permit shall be valid for sixty (60) days.

#### **4.07.110 Application for New Construction Permit**

No person shall engage in the replacement or installation of a wastewater system or treatment component without having first obtained a Construction Permit. To obtain a New Construction Permit, the owner or designated agent of the property owner shall submit the prescribed District permit application form and fee. New septic system designs require a Design Approval Permit prior to the issuance of the New Construction Permit. If the property to be served by a new wastewater treatment system is not currently provided water service by the District, then an application for water service and payment of related fees are required prior to issuance of a New Construction Permit.

**4.07.112 Design Approval Permit**

No person shall engage in the replacement or installation of a wastewater system without having first obtained a Design Approval Permit. To obtain a Design Approval Permit, the owner or designated agent of the property owner on which the proposed work is to be conducted shall first file, along with the prescribed permit application fee, an application on a District form. Every such application shall:

1. Identify and describe the work to be covered by the permit for which application is made;
2. Describe the land on which the proposed work is to be done by legal description, street address, and/or Marin County Assessor's parcel number;
3. Describe in a similar manner all parcels which are, or will be, served by the wastewater treatment system involved in the work;
4. Indicate the use or occupancy which the wastewater treatment system serves or will serve;
5. Be accompanied by plans, diagrams, computations, specifications and other data as required in this code;
6. If the application is for new construction, be accompanied by plans and specifications for the building(s) to be served by the new wastewater treatment system;
7. Be signed by the owner, or by the authorized agent of the owner, and accompanied by a document signed by the owner authorizing the agent to act on the owner's behalf;
8. If the property to be served by a new wastewater treatment system is not currently served by a District water service, be accompanied by an application for water service and payment of related fees;
9. Give such other data and information as may be required by the General Manager.
10. No person shall engage in the replacement or installation of a wastewater system without having first obtained a Construction Permit.

**4.07.114 Discharge Permit Required**

No person shall discharge into ground or surface waters located within the District, or the contiguous water bodies of the District, any sewage, waste, or other polluted waters except where suitable treatment has been provided and a discharge permit has been first issued by the District in accordance with the provisions of this code. Where more than one wastewater system (preexistent to this Code) is located on a parcel, which serves different buildings and/or units, or separate uses, then a separate discharge permit for each wastewater system shall be issued and a permit fee for each permit shall be collected. Where more than one wastewater system (preexistent to this Code) is located on a parcel, which serves one building and/or one use, then a single discharge permit shall be issued and one permit fee shall be collected.

**4.07.115 Valid Discharge Permit**

Notwithstanding any provisions contained therein, the last District discharge permit issued for a wastewater system shall continue to be valid unless, and until, subsequently revoked pursuant to Section 4.07.740.

**4.07.118 Compliance with California Environmental Quality Act**

Permits issued by the District pursuant to this code may be subject to the California Environmental

Quality Act (CEQA). The General Manager shall determine whether CEQA applies and what level of analysis and documentation it requires, and will then notify the applicant of his determination. The cost of the District's compliance with CEQA shall be borne by the applicant. The General Manager shall estimate the cost and require the applicant to furnish an appropriate deposit, and to agree to advance additional funds as required to complete the CEQA process. Failure to submit the deposit, to agree to advance the remaining costs, or to actually make further payments when required, shall constitute voluntary withdrawal of the application.

#### **4.07.130 Design Review Application**

Plans, engineering calculations, diagrams, and other data shall be submitted in three or more sets along with one reduced (11"x17") plan, with a design review application and prescribed fee for work defined as repair or replacement or work defined as new construction. If required, a variance application and prescribed fee will be submitted with the design review application. Plans and specifications shall be prepared and signed by a designer as defined in Section 4.03.215. Plans, specifications, soil profile, and percolation test logs, shall be drawn to scale upon substantial paper and shall be of sufficient clarity to indicate the location, nature, and extent of the work proposed, to indicate all existing water bodies, to indicate all relevant surface features, and to show in detail that it will conform to the provisions of this code and all relevant laws, ordinances, rules, and regulations. Specifications shall include a designer's inspection schedule as required in Section 4.07.131.

#### **4.07.131 Designer's Inspection Schedule**

The applicant's designer shall provide for such inspections during the performance of the work as may be appropriate for the District Engineer to make the certification of completion as required in this chapter. A schedule of planned inspections by the designer shall be submitted as required in this code.

#### **4.07.133 Exemption from Design Review Application – Minor System Repair**

If it is determined that the nature of minor system repair work, which shall include repair or replacement of system components exclusive of tanks or leach fields (not including subsurface drip line), is such that plans and specifications need not be prepared by a designer, then the General Manager may waive the requirement if otherwise not required by law. An application for exemption from the design review application process shall be made at the time of submittal. If the General Manager has waived the requirement for a complete design review application as specified in section 4.07.130, then the following may be submitted as alternatives:

1. Plans indicating the proposed system layout including all major design features and monitoring features.
2. Plans indicating the building envelope, detailing maximum size of the building, and showing maximum square footage.

#### **4.07.135 Determination of Complete Design Review Application**

No later than thirty days after receipt of all required application materials for Design Review, the General Manager or District Engineer shall determine in writing whether they are complete and will notify the designer and/or the applicant of that determination.

#### **4.07.215 Determination of Incomplete Design Review Application**

No later than thirty days after receipt of application materials for Design Review, if the General Manager or District Engineer determines that the application is incomplete, a notice of incomplete application shall be transmitted to the designer and/or the applicant.

**4.07.220 Approval of Design Review Application and Plans; Issuance of Design Approval Permit**

Following a determination of completeness, the design review application, including plans and specifications, shall be reviewed for conformance to the requirements of this code and other pertinent laws and regulations by the District Engineer. If the application is determined to so conform, the District Engineer shall endorse said application, along with all plans and specifications, as "APPROVED" and shall issue a Design Approval Permit. If the application requires a Variance Hearing, then the District Engineer shall issue a Design Approval Permit and endorse all plans and specifications, as "APPROVED" upon granting of the Variance request by the Board of Directors. The Design Approval Permit shall be valid for a period of three years. No extensions shall be granted.

**4.07.230 Notice to Agencies of Design Approval - New Construction**

Other governmental agencies require District approval of a proposed wastewater system to serve proposed new construction prior to considering a permit application for development of a property.

In recognition of this prerequisite, the Design Approval Permit may be sent by the District Engineer with the approval of the General Manager to other agencies when the proposed wastewater treatment system plans and specifications have been approved pursuant to Section 4.07.220. Said Design Approval Permit shall be conditioned upon final approval of the new construction project by the County of Marin and shall automatically be void should processing by the County of Marin of the application for the new construction project cease or the project submittals be denied by the County.

**4.07.310 Revocation of Design Approval Permit**

The General Manager may revoke in writing a design approval permit whenever evidence exists that the permit or approval may have been issued in error or on the basis of incorrect information supplied in the application or in violation of this code or other law or regulation. Such revocation shall require either prior or subsequent notice to the applicant by the District and an opportunity for hearing before the District Board.

**4.07.410 Retention of Plans**

Four sets of approved plans and specifications shall be retained by the District to include three standard sets of approved drawings and one reduced (11" x 17") reproducible drawing submitted by the applicant or the applicant's Designer.

**4.07.510 Licensed Contractor Required**

All work done pursuant to a Design Approval Permit shall be done by, or under the supervision of, a person holding an appropriate license as a contractor pursuant to state law. The owner may be authorized to perform permitted maintenance or repair work of a minor nature which work will not endanger the public health, nor violate any laws, ordinances, or regulations.

**4.07.610 Inspections**

The General Manager is authorized to set fees for failure to provide access for periodic inspections. In addition to any inspections performed by the District Engineer, all work for which a Design Approval Permit is required shall be subject to inspection by the General Manager or deputy in order to determine if such work conforms to the approved application, plans and specifications. All such work shall remain accessible and exposed for inspection purposes until inspected and approved and it shall be the responsibility of the owner or authorized agent to assure that required inspections are obtained. Should such work not be accessible for inspection,



neither the District nor its employees and officers shall be liable for the expense entailed in the removal or replacement of any material required to allow inspection. A survey of the parcel may be required to verify that the construction work is located in accordance with approved plans. Approval as a result of an inspection shall not be construed to be an approval of a violation of the provisions of this code or other laws, ordinances or regulations.

#### **4.07.620 Certification by Designer**

Upon completion of work performed pursuant to the Design Approval Permit, and prior to issuance of a Discharge Permit, the designer shall certify that the work was performed pursuant to the District approved plans and specifications, as specified in Section 4.07.220, in the form specified below:

I [name of designer, professional title, and state registration number] do hereby certify that based upon my inspections of the work performed on the wastewater treatment system pursuant to the repair/ construction permit issued on [date permit issued] conformed to the plans and specifications prepared by me as approved by the Stinson Beach County Water District.

This certification shall be dated and signed under penalty of perjury.

#### **4.07.630 Certification of As-Built Plans**

If the system was not installed as originally drawn, the designer shall submit as-built plans indicating all variations approved by the District Engineer and shall certify those plans in accordance with Section 4.07.620.

#### **4.07.710 Discharge Permit**

Upon completion and final inspection of work performed pursuant to a Design Approval Permit and receipt of certification by the designer, a Discharge Permit shall be issued and recorded with the Recorder of the County of Marin. Said Discharge Permit shall be conditioned upon the maintenance of, and the continued proper operation of, the wastewater treatment system as designed and constructed, upon payment of periodic permit fees and inspection fees, upon periodic inspections of said wastewater treatment system, and upon continuation of the use for which the system was designed. Every Discharge Permit shall indicate the design flows of the system.

#### **4.07.720 Periodic Inspection**

Every wastewater treatment system for which a Discharge Permit has been issued shall be inspected by the General Manager or deputy approximately every two (2) years. Depending upon the design and condition of the system, inspections may be more frequent or less frequent. The frequency of inspection shall be specified on the current repair order.

#### **4.07.725 Accessibility for Periodic Inspection**

Upon notification from the District, owners are required to have all elements accessible for inspection, including access to the septic tank, sump tank, diversion valves, sand filter, leach field(s), alarms, panels, monitoring wells, and pumps. All riser lids shall weigh less than twenty-five pounds. All gates shall be unlocked and padlocks on panels or lids shall be removed prior to the inspector's arrival. All hatches must be easily removable. Deck hatches that weigh more than twenty-five pounds must be removed. If screwed down, all screws shall be removed prior to the inspection. Any obstructions, such as monuments and birdbaths that limit access must be removed. Pets must be confined during the inspection.

#### **4.07.730 Purpose of Periodic Inspection**

The purpose of a periodic inspection as provided in Section 4.07.720 shall be to determine the effectiveness of the wastewater treatment system in treating wastewater before it enters the groundwater. Factors to be evaluated relate to the design of the system, the nature and quantity of flow of wastewater entering the system, the condition and effectiveness of the components, the quality and condition of the soils into which wastewater is discharged, and the quality and nature of the groundwater receiving the discharge. Where found to be desirable, sampling wells may be required to be installed in and around the wastewater treatment system. Evaluation of the system shall be generally compared to the expected performance of the system as designed, compared to the expected performance of a new system installed in conformance to requirements for a replacement system, and related to the operation and maintenance requirements discussed in the *Minimum Guidelines* and the *Design Manual*.

#### **4.07.732 Scope of Periodic Inspection**

The scope of a periodic inspection shall include, but is not limited to:

1. Verification of system component locations
2. Diversion valve operation, pump runs, float operation and valve operation
3. Verification of installation of mosquito abatement equipment including screening of all waste vents and proper sealing of all septic tank risers
4. Measurement of scum and sludge depth
5. Inspection for possible ponding, standing water, breakout, and noticeable odors
6. Examination of tank structure, pumps, and floats
7. Performance of hydraulic loading to verify the timing of leach field hydraulic acceptance
8. Monitoring of pump timers

All necessary procedures shall be performed in order to determine to the satisfaction of the inspector that the septic system is operating within health and safety parameters.

#### **4.07.733 Notification of Completed Inspection**

Upon completion of a periodic inspection, the District shall issue a Notification of Completed Inspection listing all required repair(s) and/or maintenance item(s), if any. The property owner(s) shall comply with all conditions within the required timeframe.

#### **4.07.735 Change of Use**

If an owner proposes a change of use for a wastewater treatment system, the General Manager or District Engineer may require the owner to demonstrate that the current system is adequate for the proposed use change and that the new use will not hasten deterioration of the system and will not degrade the surface or groundwater of the District. The General Manager or District Engineer may require the owner to submit a study/review of the system by an appropriately licensed designer so that the General Manager or District Designer can make an informed decision regarding the possible effects of the proposed change of use. The General Manager or District Engineer may require that the owner modify the system to provide an additional level of treatment to adequately treat the wastewater prior to disposal.

#### **4.07.740 Revocation of Discharge Permit and Failed System Citation**

When it has been determined that a wastewater treatment system for which a Discharge Permit has been issued is operating in violation of this code, operating in a manner not consistent with its design (such as frequently exceeding the design average or maximum daily flow rate), or is discharging wastewater in a manner which may result in the contamination of surface water, ground water, or the contiguous water bodies of the District, or contains components that do not

conform to this code, or to which access for inspection has been denied, or which has not complied with specified repair order items, the Discharge Permit may be revoked upon written notice to the owner. If the owner, upon receipt of said notice revoking the Discharge Permit, does not appeal as provided in Section 4.05.060 or if upon appeal, the Board of Directors determines that the revocation shall be upheld, a failed system citation shall be issued to the owner and recorded with the County of Marin thirty days from the date of permit revocation.

#### **4.07.745 Re-issue of Discharge Permit**

Upon completion of system repairs and determination by District staff that the system is no longer in violation of this code, the Discharge Permit will be re-issued and recorded with the County of Marin. Discharge Permits shall also be re-issued in cases of ownership change.

#### **4.07.760 Grading Permit Application**

Marin County Grading Permit applications are subject to the review and approval by both County and District staff. The grading plans shall conform to Section 7006 (G) of the Uniform Building Code and shall indicate the approximate location of wastewater system 200 feet of the proposed grading improvements. When excavation is necessary for work to be performed pursuant to a New Construction or Maintenance Permit, a County Grading permit is not applicable.

The person reviewing an application on behalf of the District may request additional supporting data as needed. Such supporting data may include materials and studies as provided in Section 7006 (D) of the Uniform Building Code and as suggested in the Design Manual.

#### **4.07.770 Other Permits**

Aside from an individual sewage treatment system discharge permit, additional permit(s) will be required by the Marin County Building Inspection Department for electrical pump installations.

## Chapter 4.12: LAND DIVISION STANDARDS

### **Sections:**

- 4.12.010 Requirements
- 4.12.020 Field Testing
- 4.12.030 Documentation
- 4.12.040 Monumentation of Dispersal Area
- 4.12.050 Certification
- 4.12.060 Land Division Plan – Tentative Map

### **4.12.010 Requirements**

Requirements for processing information necessary for approval of a septic system for a tentative map or a new subdivision (two or more parcels) shall be the same as the general requirements for wastewater systems. All subdivision submittals shall include a report of localized groundwater mounding and of generalized and localized nitrate accumulations for each parcel and for the subdivision as a whole to insure that no septic system will affect other parcels. No parcels shall cause a nitrate concentration higher than 10 mg/l to any adjoining property.

### **4.12.020 Field Testing**

All soil exploration holes, groundwater determination holes, and percolation test holes shall be clearly identified in the field and on a plan as to hole number and lot number.

### **4.12.030 Documentation**

Percolation test information shall be submitted in a separate format for each proposed lot. The lot-by-lot information may be bound into an overall septic system site assessment for the entire subdivision. The lot-by-lot information shall include percolation tests for that lot using the same numbering as in the field and on a wastewater plan. Soil profiles logs and site plans for each of the proposed sewage treatment areas shall show information as specified in Section 4.07.130.

### **4.12.040 Monumentation of Dispersal Area**

The area tested shall be marked by placing a six foot minimum steel fence post at least four feet into the ground at the two (or more) profile holes for each percolation test site. The fence posts shall be located with distances from at least two prominent, permanent, and readily identifiable property features. Areas tested for sewage treatment shall be delineated on the final map or parcel map. These areas shall be accurately tied to the fence posts marking the leach field area.

### **4.12.050 Certification**

The individual certifying the test shall indicate the boundaries of the acceptable dispersal field site and shall certify that each lot has sufficient area to accommodate dispersal for at least a 1,400 square foot home, plus a 100% built secondary area, and a 100% fail safe area.

### **4.12.060 Land Division Plan - Tentative Map**

The plans of the proposed site development shall show all road cuts, driveway cuts, grading, structures, drainages, and drainage improvements along with the dispersal fields. An overall map

of the subdivision shall be submitted with submittal of the percolation test data. This map shall clearly indicate location of field tests, proposed building site, proposed individual or mutual lot configuration, and all proposed and existing improvements. All items listed as requiring setbacks in this code shall be shown on this plan.

## Chapter 4.13: VARIANCES TO DESIGN STANDARDS

### **Sections:**

- 4.13.010 Variances to Design Standards
- 4.13.100 Variance Application and Fee
- 4.13.110 Submission to Regional Water Quality Control Board
- 4.13.120 Variance Hearing
- 4.13.125 Notification of Neighboring Property Owners
- 4.13.130 Finding of Facts – Alternative Wastewater System
- 4.13.131 Finding of Facts – Alternative Wastewater System for Repair or Replacement of Failed System
- 4.13.140 Variance Conditions and Expiration

### **4.13.010 Variances to Design Standards**

Upon making certain findings in each case as set forth in Section 4.13.130 or Section 4.13.131, the Board of Directors, except as otherwise provided in this code, may grant variances to the design standards established in this code for a particular system design based upon the unique characteristics of the case. The granting of a variance in one case shall not constitute a precedent for a subsequent case.

### **4.13.100 Variance Application and Fee**

The owner or agent shall submit an application for a variance on a District form and shall pay the prescribed variance application fee. The variance application shall be submitted with the design review application.

### **4.13.110 Submission to Regional Water Quality Control Board**

Excepting applications which meet the requirements of Section 4.13.131 and upon making a determination that the application is complete pursuant to Section 4.07.110, and that the application conforms to the requirements of this code in all aspects except for the item(s) subject to variance, a copy of the application shall be transmitted to the Executive Officer of the California Regional Water Quality Control Board, San Francisco Bay Region allowing for a thirty day response time.

### **4.13.120 Variance Hearing**

A public hearing before the Board of Directors shall be held at the next regular meeting that falls at least thirty days after the submission of the application to the Regional Water Quality Control Board. A notice of the hearing shall be posted and mailed to the address of the applicant.

### **4.13.125 Notification of Neighboring Property Owners**

Excepting applications which meet the requirements of Section 4.13.131 and upon a determination that an application for variance is complete, and the setting of a date for hearing of the application before the Board of Directors, notice shall be sent, by the District, to the last known address of each property owner within three hundred (300) feet of the property that is the subject of the variance request. The notice shall be sent by first class mail at least 14 days prior to the date of the hearing. The notice shall specify the section(s) of the code from which the applicant is applying for a variance and shall notice the date, time, and place of the hearing. Re-notification of

continued hearing dates shall be made in the same manner as above unless the hearing is continued at a regular meeting of the Board of Directors to a specified future date.

#### **4.13.130 Finding of Facts – Alternative Wastewater System**

The purpose of the hearing on a variance shall be to allow the applicant to present a statement and adequate evidence, in such form as the Board may require, demonstrating that all of the following conditions exist:

1. Special circumstances and conditions exist on the property that makes strict compliance with the regulation inappropriate;
2. The variance is necessary for the preservation and enjoyment of a substantial property right;
3. The variance, if granted, would not result in a cumulative adverse detrimental effect on surface or ground waters;
4. The variance will not materially adversely affect the condition of adjacent watercourses or wetlands, the conditions of subsurface water under adjacent properties, the health or safety of persons residing or working in the neighborhood of the property, and/or the general health and safety of the public.

In the event that the Executive Officer of the Regional Water Quality Control Board has commented in opposition to the granting of the variance or has required additional findings, then the applicant shall submit revised plans which mitigate the conditions forming the basis of opposition or which address the required additional findings.

Following the public hearing, the Board may grant the variance only if by resolution it makes the findings of facts specified herein above.

#### **4.13.131 Findings of Fact – Alternative Wastewater System for Repair or Replacement of Failed System**

The purpose of the hearing on a variance shall be to allow the applicant to present a statement and adequate evidence, in such form as the Board may require, demonstrating that all of the following conditions exist for the repair or replacement of a failed wastewater system which does not include New Construction:

1. Conditions exist on the property which prevent the repair or the construction of a replacement system pursuant to a design which conforms to this code.
2. The conditions referred to in number one above are natural conditions, which cannot be altered such as depth to groundwater or are conditions which could not reasonably be modified such as insufficient space on the parcel which could only be corrected by significantly altering a building which was constructed pursuant to a permit issued by the County of Marin.
3. The design represents the least deviation from the design standards reasonably possible.
4. The design incorporates measures to mitigate possible reduced effectiveness of treatment using alternative systems or other measures as approved by the Board.

**Following the public hearing, the Board may grant the variance only if by resolution it makes the findings of facts specified herein above.**

**4.13.140 Variance Conditions and Expiration**

In granting a variance, the Board may establish such conditions in connection that will, in its opinion, substantially secure the objectives of the design requirements to which the variance applies. In all cases in which variances are granted, the Board shall require such evidence and guarantees as it may deem necessary. The variance approval shall become effective upon the granting of a Design Approval Permit. The variance approval shall expire three (3) years from the date of the Design Approval Permit. No extensions shall be granted.



## Chapter 4.15: DESIGN: STANDARD SYSTEMS

### **Sections:**

4.15.010	General
4.15.050	Design Practices
4.15.060	Construction Practices
4.15.100	Site Criteria - Setbacks
4.15.111	Depth to Groundwater
4.15.121	Soil Depth
4.15.131	Minimum Percolation Rate
4.15.141	Ground Slope
4.15.151	Cover
4.15.161	Cover Fill Systems
4.15.181	Drainage Improvements
4.15.200	Site Evaluation
4.15.203	Designer Required
4.15.205	Wet Weather Testing Period
4.15.206	Wet Weather Groundwater Tests
4.15.207	Wet Weather Percolation Tests
4.15.221	Soil Profile
4.15.224	Percolation Testing
4.15.225	Percolation Test Procedures
4.15.230	Groundwater Mounding Analysis
4.15.235	Nitrate Loading Analysis
4.15.240	Repair and Replacement Systems - Previous Site Evaluation
4.15.300	Septic Tank Construction and Size
4.15.310	Septic and Sump Tank Design Standards
4.15.320	Septic Tank Installation
4.15.330	Connections to Septic Tank
4.15.600	Dispersal Field Design
4.15.603	Trench Layout
4.15.621	Design Flow
4.15.625	Drainage Improvements
4.15.630	Surface Flows
4.15.635	Subsurface Flows
4.15.640	Dispersal Fields
4.15.650	Pressure Dosed Distribution
4.15.660	Serial Distribution
4.15.670	Sizing for Standard and Pressure Distribution Dispersal Fields
4.15.680	Trench Dimensions
4.15.690	Depth of Trench
4.15.700	Effective Wall Trench
4.15.705	Chambers
4.15.710	Trench Tolerance
4.15.720	Trench Width
4.15.730	Required Cover
4.15.740	Pumps or Dosing Siphons
4.15.750	Sump/Pump Tanks

- 4.15.760 Hydraulic Design for Pressure Distribution Systems
- 4.15.770 Diversion Valve
- 4.15.780 Monitoring Wells
- 4.15.790 Piping
- 4.15.800 Pressure Piping
- 4.15.810 Thrust Blocks
- 4.15.820 Gravel
- 4.15.830 Filter Fabric
- 4.15.900 Use of Intermittent Sand Filters
- 4.15.910 Site Criteria
- 4.15.930 Leach Field Sizing for Intermittent Sand Filter Systems
- 4.15.940 Intermittent Sand Filter Design Standards
- 4.15.950 Intermittent Sand Filter Design Flow
- 4.15.960 Leach Field Design: General
- 4.15.970 Raised-Bed Leach Field Design
- 4.15.980 Maintenance Program and Maintenance Design Features
- 4.15.990 Maintenance Design Features
- 4.15.995 Maintenance Program

**4.15.010 General**

Standard systems shall be designed and constructed as provided for in this chapter. Except where otherwise indicated, the design standards shall apply uniformly to wastewater treatment systems constructed to serve new construction and to the repair and replacement of an existing system. Where the standards differ, it is the intent of the District that to the extent reasonably possible, a design should conform to standards for new construction.

**4.15.050 Design Practices**

In addition to the provisions of this code, and where not contrary to this code, the wastewater treatment system design practices accepted by the District may be found in the Minimum Guidelines and the Design Manual.

**4.15.060 Construction Practices**

In addition to the provisions of this code, and where not contrary to this code, the wastewater treatment system construction practices accepted by the District may be found in the Minimum Guidelines, the Design Manual, and the most current edition of the *Uniform Plumbing Code* as published by the *International Association of Plumbing and Mechanical Officials* adopted by the County of Marin.

**4.15.100 Site Criteria - Setbacks**

Minimum horizontal distances between other site features and the septic tank and the edge of the drain field shall be as follows:

Site Feature	Septic Tank	Dispersal Field
Buildings	5 feet	10 feet
Property Line	5 feet	5 feet
Downslope Property Line	10 feet	25 feet (Note 1)
Wells (domestic and non-domestic)	100 feet	100 feet

Watercourses & Water Bodies	50 feet (Note 4)	100 feet
Drainage Ways	50 feet	50 feet
Cut or Embankment or Bluff	10 feet	(Note 2)
Unstable Land Forms	50 feet	50 feet
Swimming Pools/Hot Tubs	10 feet	15 feet
Public Water Main (Domestic)	10 feet	10 feet
Water Laterals	(Note 3)	(Note 3)
Driveway/Parking/Paved Areas	(Note 5)	5 feet
Septic Tank/Sump Tank/Pretreatment Unit	-	5 feet

NOTE 1: Setback distance shall be 50 feet if the property line is one where there is a reasonable chance that a cut bank could be excavated for a house or road construction.

NOTE 2: Setback in feet to be four times the vertical height of the cut, embankment, or bluff, or 100 feet, whichever is less, but in no case less than 25 feet.

NOTE 3: Setback shall be five feet for a septic tank and ten feet for a drain field, or one foot for either where schedule 80 P.V.C. pipe or better grade is used and an approved backflow prevention device is installed.

NOTE 4: Setbacks from watercourses and water bodies shall be consistent with Local Coastal Program, Unit 1 (1980) Policies on Stream Protection, Policy 3, page 19, codified in Marin County Code, Title 22, section 22.56.130 G.3 (1983), and Marin County Countywide Plan (1994), Policies EQ-2.1, EQ-2.2, EQ-2.3, EQ-2.3a and Figure EQ-3. It is not permissible to add soil fill to achieve the required setback to watercourses and/or water bodies.

NOTE 5: Setbacks from septic/sump tanks to driveway, parking, and paved areas shall be 5 feet except for District approved traffic rated tanks, risers, and covers

**4.15.111 Depth to Groundwater**

The minimum depth to the highest seasonal elevation of the groundwater from the bottom of the dispersal field trench shall be as follows:

<u>Percolation Test Rate</u>	<u>Depth</u>
Slower than 5 minutes per inch	3 feet
Faster than 5 minutes per inch	20 feet*

\* except where soil profile justifies a lesser depth or for use of a District approved pretreatment device

The soil depth requirements listed above refer to the natural composition of the existing soil. It is not permissible to import soil to meet minimum depth requirements to groundwater, except pursuant to Sections 4.15.910 (Site Criteria) and 4.15.970 (Raised-Bed Leach Field Design).

#### **4.15.121 Soil Depth**

The minimum depth of suitable soil below the bottom of the drain field trench shall be three feet. The soil depth requirement refers to the natural composition of the existing soil. It is not permissible to import soil to meet the minimum depth requirement except pursuant to Sections 4.15.910 (Site Criteria) and 4.15.970 (Raised-Bed Leach Field Design)

#### **4.15.131 Minimum Percolation Rate**

The percolation rate of soils in the treatment area shall not be slower than 120 minutes per inch.

#### **4.15.141 Ground Slope**

Where the proposed leach field ground slope exceeds 20%, the design submittals shall be accompanied by a geological engineering report demonstrating that the proposed design will not create a public health hazard or jeopardize the building site or contiguous properties. The ground slope criteria refers to the existing landform. It is not permissible to grade to achieve a reduction in ground slope.

#### **4.15.161 Cover Fill Systems**

Where soil and/or groundwater conditions require shallow trench placement, soil fill may be used to satisfy dispersal field cover requirements. Such fill systems shall comply with all system requirements as well as the following:

1. The maximum allowable ground slope shall be 18%.
2. The percolation rate shall not be slower than 60 minutes per inch.
3. The drain rock and perforated pipe sections shall be installed entirely within native soil.
4. Prior to placement of fill material, all vegetation shall be removed and the ground surface disked or plowed to permit good mixing of native soil and fill material.
5. Sand, gravel, or rock may not be used for cover fill. The soil used for fill shall be similar in texture to the native soil.
6. Fill shall be placed in layers of not more than eight inches and compacted to approximately the same dry density as the native soil. Alternative compaction procedures may be allowed in accordance with recommendations and technical data supplied by a designer.
7. The fill shall be continuous, constructed to a uniform depth over the dispersal fields as specified in section 4.15.151, shall extend a minimum distance of 15 feet in any direction from the center of any trench, and shall be completed with a toe tapered at no less than a 5:1 ratio.

#### **4.15.181 Drainage Improvements**

Surface and sub-surface drainage waters may not be artificially diverted from the dispersal field area except as provided in Section 4.15.625.

#### **4.15.200 Site Evaluation**

Site evaluations shall be performed on all parcels for which a wastewater treatment system is proposed. A site evaluation shall include a profile inspection and percolation testing.

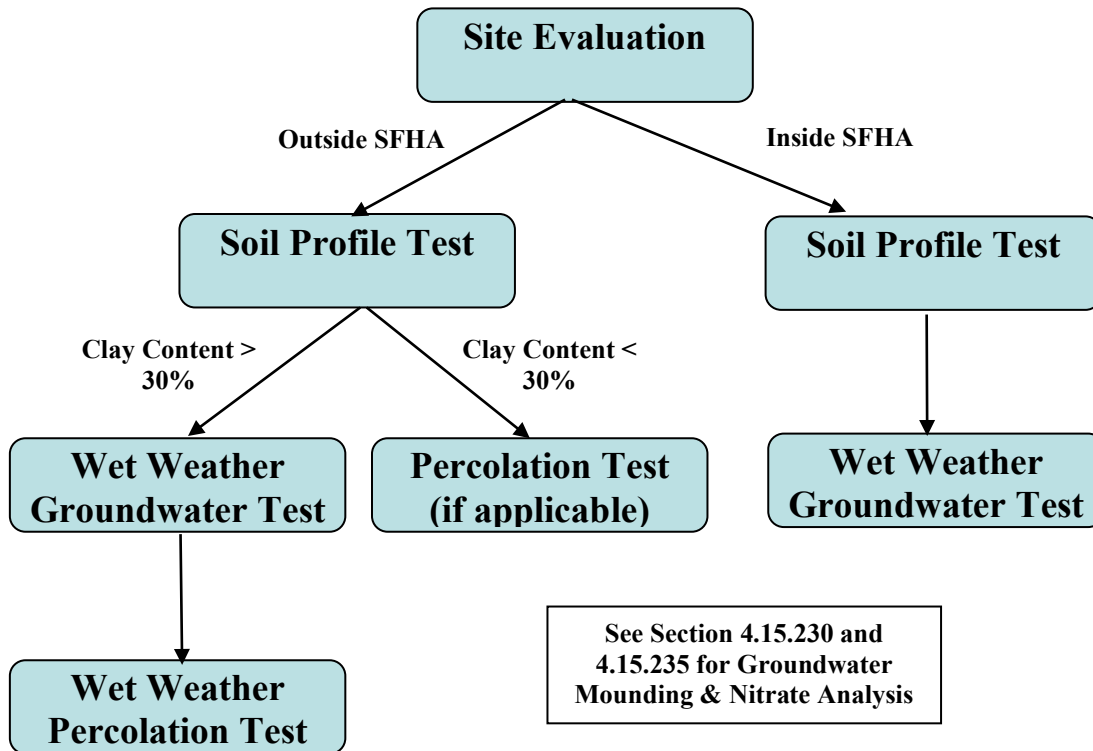

**4.15.203 Designer Required**

Site evaluations, and the designs based thereon, shall be performed by, or performed under the direct supervision of a designer.

**4.15.205 Wet Weather Testing Period**

The wet weather period shall be determined annually by the General Manager between January 1<sup>st</sup> and May 1<sup>st</sup> after 50% of the average annual rainfall has fallen. Average annual rainfall measurement begins on the previous first day of July. If 50% of the average annual rainfall has not fallen or a rainfall of 0.8 inches in a 48 hour period does not occur between January 1<sup>st</sup> and May 1<sup>st</sup>, then the wet weather testing period will not open.

**4.15.206 Wet Weather Groundwater Tests**

Wet weather determination of groundwater levels shall be required within the Special Flood Hazard Area except when the District Engineer has determined that there is adequate documentation of groundwater levels. Wet weather determination of groundwater levels outside the Special Flood Hazard Area shall be determined during the soil profile investigation with the District Engineer. This determination will be based on the presence of clayey soils (greater than 30% clay) with high shrink-swell potential (plasticity index greater than 20 ASTM D4318-84).

Wet weather groundwater testing shall occur within the wet weather testing period ten (10) calendar days following a rainfall of 0.8 inches in a 48-hour period. A minimum of three (3) groundwater level inspections shall be made by District staff. The owner shall install a minimum of two (2) monitoring wells, one in each of the proposed leach fields. The monitoring well shall be a 2" to 4" diameter slotted or perforated pipe installed 3 feet below the proposed bottom of the leach field. Upon installation of the monitoring wells, submittal of the Site Review application, and

payment of the Site Review fee, the owner shall notify the District to commence groundwater testing.

#### **4.15.207 Wet Weather Percolation Tests**

Wet weather percolation testing shall be determined by the District Engineer based on the presence of clayey soils (greater than 30% clay) with high shrink-swell potential (plasticity index greater than 20 ASTM D4318-84) during the soil profile investigation. Wet weather percolation testing shall occur within the wet weather testing period (See Section 4.15.225 for percolation test procedures).

#### **4.15.221 Soil Profile**

Soil conditions shall be evaluated by direct inspection of the soil profile of the primary and secondary treatment areas, using backhoe excavations, hand auger, and/or core sampling. The soil profile shall be inspected to a depth of at least three feet below the bottom of the proposed treatment system. At least one backhoe excavation or two borings in each of the primary and reserve area is required. Information provided from the profile shall include the following:

1. Thickness, depth, and texture of soil layers encountered;
2. Depth to bedrock, hardpan, or other impermeable layer;
3. Depth to groundwater;
4. Evidence of soil mottling; and
5. Other conditions affecting the potential use of the soil for sewage treatment including, but not limited to, evidence of roots, fissures, dampness, structure, and stoniness. Depth to groundwater shall be determined during a wet weather testing period, except in areas determined by the General Manager to have adequate documentation of groundwater conditions.

The soil profile and textural requirements specified refer to the natural composition of the existing soil mantle. It is not permissible to import soil to meet textural requirements.

#### **4.15.224 Percolation Testing**

Percolation tests shall be conducted to determine the design loading rate. Such tests shall be conducted in the wet weather testing period when the treatment areas are determined from soil profile information or other information to have clayey soils (greater than 30% clay) with high shrink-swell potential or potential soil saturation problems. All percolation test procedures shall follow the procedures specified in Section 4.15.225. The District may determine that a percolation test is not required in cases where the system's proposed location is in sandy or non-cohesive soils.

#### **4.15.225 Percolation Test Procedures**

Percolation tests shall be scheduled with, and attended by, SBCWD personnel. The applicant shall allow forty-eight hours for scheduling of the percolation test(s). Percolation tests are to be carried out in soils in their native state at the proposed depth of the soil absorption field and at lesser depths. A minimum of six passing tests shall be required for each property as depths respective to the effective wall of the dispersal trench. Three of the passing percolation tests shall be conducted at the proposed trench depth or deeper. Percolation tests may be conducted at the bottom of backhoe or other excavation holes where deeper testing is required. Additional percolation testing or textural analysis of deeper soil zones may be required to determine if underlying soils have adequate permeability.

Individual tests shall be run in six-inch diameter holes dug or bored using hand tools. If power-based tools are used, any smeared soil surfaces shall be removed from the sides of the hole. Loose material shall be removed from the bottom of the hole and two inches of fine gravel shall be added to protect the bottom from scouring.

If soils tend to collapse, a perforated pipe shall be placed in the hole and carefully packed gravel shall be placed between the pipe and the hole wall. Where gravel pack is needed, the percolation rate shall be adjusted for the water displacement attributable to the gravel and perforated pipe. The adjustment factor shall be computed based upon determination of the actual percentage of void space in the gravel pack portion of the test hole.

Presoaking is required in all tests. The water shall be carefully placed within the hole. Water shall be added to at least a twelve-inch (12") depth over the gravel and maintained at this level for at least four hours, preferably overnight. If the soil is known to have a low shrink-swell potential (clay content 15% or less) testing may proceed after the four hour presoak for a minimum of four hours.

Soils with higher shrink-swell potential are to be tested the following day and in any case within 24 hours of presoaking as follows:

1. Fill the hole with clean water (no chemical additives) approximately six inches above the gravel (or eight inches above the bottom of the hole).
2. Using a secure fixed reference and timepiece to determine the time for the water to recede one inch or determine the drop of water after an interval of 30 to 60 minutes.
3. Refill, record information, and repeat the process. Test for a minimum of two hours if rates have stabilized. Stabilized rates shall be two consecutive rates in minutes per inch within 10% of each other. If rates have not stabilized in two hours, continue testing until such time that rates stabilize. If rates do not stabilize at four hours, discontinue testing.
4. Use the last water level drop to calculate the percolation rate.
5. Time lapse between test intervals shall be a minimum of five to ten minutes.
6. Test results shall be reported in units of minutes per inch.

The percolation test rate shall be determined by averaging at least six passing tests conducted in or near the proposed drain field of which at least three of the test holes will be at the bottom depth of the proposed drain field. This average shall be used for determining the appropriate loading rate from the table in Section 4.15.670.

#### **4.15.230 Groundwater Mounding Analysis**

An analysis of the localized groundwater mounding shall be prepared for parcels within the Special Flood Hazard Area if all of following conditions exist:

1. Groundwater is within 36 inches from existing grade, and;
2. Proposed septic system is located on a parcel size with less than 5,000 ft<sup>2</sup>, and;
3. Proposed septic system is located within 50 feet to an existing septic system.

The groundwater mounding analysis shall demonstrate a 36 inch minimum vertical separation from groundwater to the leach field.

#### **4.15.235 Nitrate Loading Analysis**

An analysis of the nitrate loading shall be prepared for parcels within the Special Flood Hazard Area if all of following conditions exist:

1. Groundwater is within 36 inches from existing grade; and
2. Proposed septic system is located on a parcel size with less than 5,000 ft<sup>2</sup>; and
3. Proposed septic system is located within 50 feet to an existing septic system.

The nitrate loading analysis shall demonstrate the proposed septic system shall not exceed the localized nitrate concentration beyond 10 mg/L.

#### **4.15.240 Repair and Replacement Systems - Previous Site Evaluation**

Where the District has on file the soil profile, and percolation test information described above on an existing wastewater treatment system, the General Manager may waive the requirement to obtain new information prior to designing or carrying out repairs or installing a replacement system.

#### **4.15.300 Septic Tank Construction and Size**

Septic tanks shall be constructed as provided in Appendix I of the Uniform Plumbing Code excepting that steel tanks are prohibited. No septic tank shall be smaller than 1,500 gallons and shall be equipped with an effluent filter of an approved type. Unless approved by the District Engineer for use with a traffic rated tank, tank lids shall not weigh more than 25 pounds and must be securely fastened to access risers of an approved type. All maintenance covers shall be removable and shall be gas and watertight.

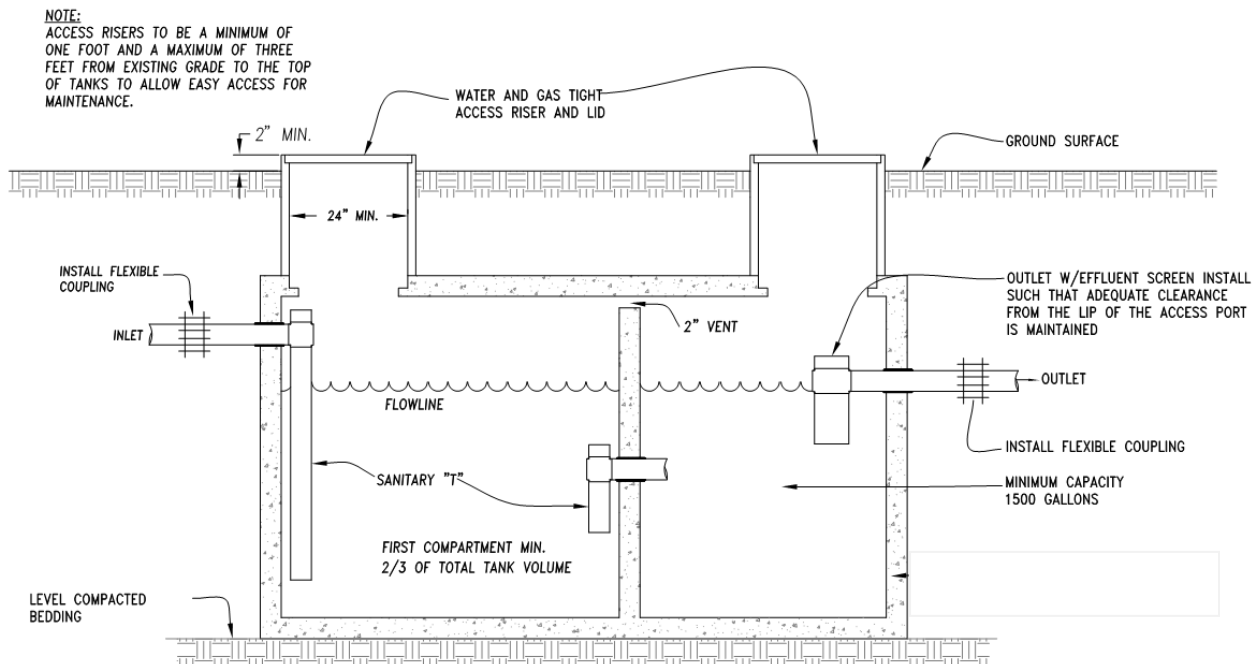

**TYPICAL SEPTIC TANK DETAIL**

#### **4.15.310 Septic and Sump Tank Design Standards**

All tanks shall meet all of the following design standards:

1. The septic tank capacity shall be equal to at least three times the maximum daily design flow, or 1,500 gallons, whichever is larger.



2. The sump tank capacity shall be equal to 100% of the daily maximum flow and dose volume.
3. If a pump is utilized in a sump tank, it shall have a 1/8" screen and be capable of delivering the design volume of effluent to the sand filter based upon design head; controls shall be of an approved type and shall include an approved elapsed time meter and a dose counter for providing information sufficient to verify compliance with design flow standards; an alarm system of an approved type shall be installed to provide a visual and audible warning that effluent in the secondary tank is in the capacity reserved for emergency storage.
4. All traffic rated tanks, risers, and covers shall be capable of supporting 20 tons and meet Uniform Plumbing Code requirements.
5. The septic and sump tank shall be constructed of either District approved concrete ,fiberglass, or plastic.
6. Unless approved by the District, fiberglass and plastic tanks shall not be installed within the Special Flood Hazard Area. Approval of the fiberglass and plastic tanks may be granted on case by case basis due to limited or no access to the tank location.

**4.15.320 Septic Tank Installation**

Septic tanks shall be installed such that access ports or openings are at least twelve inches below grade with risers which reach two (2) inches minimum above the ground surface. Septic tanks shall be installed level on a solid bed and in no case shall the depth be greater than the manufactures limits of cover. Soil around the tank shall be hard-compacted or jetted. District approved access risers and lids shall be installed.

**4.15.330 Connections to Septic Tank**

Connections to a septic tank shall be made in a manner consistent with the Uniform Plumbing Code.

**4.15.600 Dispersal Field Design**

Except as otherwise provided herein, the design and installation of the dispersal field to serve new construction shall conform to the provisions of the Minimum Guidelines and, where not in conflict with said Minimum Guidelines, the Uniform Plumbing Code.

**4.15.603 Trench Layout**

Trenches shall be placed on contour, perpendicular to groundwater flow patterns. Layout shall maximize the spreading of effluent in the dispersal field area. No single trench shall be more than one hundred (100) feet in length.

**4.15.621 Design Flow**

Notwithstanding the number of Bedrooms within a single dwelling unit, the minimum dispersal field area shall be based upon total floor area of habitable space and upon the following wastewater generation rates.

Dwelling Unit Total Floor Area	Peak Flow Per Day	Average Flow Per Day
0 to 1400 ft <sup>2</sup>	150 gallons	100 gallons
1401 to 1900 ft <sup>2</sup>	300 gallons	200 gallons
1901 to 2800 ft <sup>2</sup>	450 gallons	300 gallons
2801 to 3300 ft <sup>2</sup>	600 gallons	400 gallons

The designer may design the dispersal area for greater discharges; however, peak, and average

flows may not deviate from the above table. The flow of water to the septic system will be monitored. Flows in excess of the above rates may result in a citation being issued to the property owner. Failure by the owner to assure flows do not exceed the above rates may result in the termination of water service to the property and/or revocation of the wastewater discharge permit. Where peak flows are designed to be in excess of 600 gallons per day or average daily flows are designed to be in excess of 400 gallons per day, the design standards shall be considered a variance in accordance with Section 4.19.050.

#### **4.15.625 Drainage Improvements**

Surface and sub-surface drainage shall be diverted away from the dispersal field area.

#### **4.15.630 Surface Flows**

Any concentrated drainage flow from buildings, yards, drives, etc., shall be diverted away from the dispersal field area. This may require site grading and installation of a diversion ditch or berm on the upslope side of the drain field area.

#### **4.15.635 Subsurface Flows**

The use of intercept drains to lower the level of perched groundwater in the immediate drain field area shall be acceptable under the following conditions:

1. Natural ground slope is greater than 5%.
2. Site investigations show groundwater to be perched on a clearly definable layer of bedrock, hardpan, or impermeable soil.
3. The intercept drain shall be installed on the upslope side of the leach field area.
4. The intercept drain shall be a minimum of twelve inches wide and shall extend from the ground surface into bedrock, hardpan, or the impermeable soil layer a minimum of six and a maximum of 96 inches (eight feet), provided no hardpan or impermeable soil is encountered.
5. Pervious sections of the intercept drain shall be separated from the leach field and septic tank as follows:
  - a. Up slope minimum of 15 feet
  - b. Lateral minimum of 25 feet
  - c. Downslope minimum of 50 feet
6. The bottom and downslope side of the intercept drain shall be lined with plastic film having a minimum thickness of 12 millimeters.
7. The drainage trench shall be filled with 3/4 to 1-1/2 inch drain rock, with perforated four inch drainpipe along and two inches above the bottom of the trench.
8. Filter fabric or other suitable filter material shall be placed immediately above the drain rock.

#### **4.15.640 Dispersal Fields**

All dispersal field designs shall have two fields, each of which are 100 percent of the design loading with an approved diversion valve or valves between each field.

#### **4.15.650 Pressure Dosed Distribution**

Pumped pressure dose distribution designs require the average percolation rate be between 6 and 120 minutes per inch. A District approved pretreatment device, as defined in Section 4.03.260, or greater separation to groundwater, as listed in Section 4.15.111, shall be required for average percolation rates faster than 5 minutes per inch.

Pressure dosed distribution piping shall have:

1. 1.25" minimum inside pipe diameter
2. 1/8" minimum orifice diameter
3. Orifice shields for upward holes
4. Gate valves to adjust the orifice squirt height

**4.15.660 Serial Distribution**

Serial distribution (gravity flow) systems require the average percolation rate between 6 and 60 minutes per inch.

**4.15.670 Sizing for Standard and Pressure Distribution Dispersal Fields**

Dispersal fields shall be sized based on the minimum soil loading rate shown on the table below. This table gives the relationship for average percolation rate of six or more holes and the design loading rates. Percolation faster than 1 minute per inch or slower than 120 minutes per inch shall not be included within the average percolation rate.

Average Percolation Rate Min/inch	Design Loading Rate Gal/ft <sup>2</sup> /Day
Less than 1	system prohibited
3	1.2*
10	0.8
24	0.6
30	0.56
45	0.45
60	0.35
90-120	0.2
>120	system prohibited

\* District approved pretreatment devices are required for average percolation rate faster than 6 Min/inch

**4.15.680 Trench Dimensions**

Trench spacing shall be no less than six feet from center of one trench to the center of the neighboring trench. Areas with slopes greater than 20 percent shall have minimum trench spacing as follows:

Slope	Minimum Trench Spacing
0-20 percent	6 feet
21-25 percent	7 feet
26-30 percent	8 feet
31-35 percent	9 feet
> 36 percent	10 feet

**4.15.690 Depth of Trench**

Depth of the trench is determined in part by the depth of the percolation test depths required in Section 4.15.225. The bottom of trench shall maintain a three foot separation to impermeable soils and seasonal high groundwater conditions as required in Section 4.15.111.

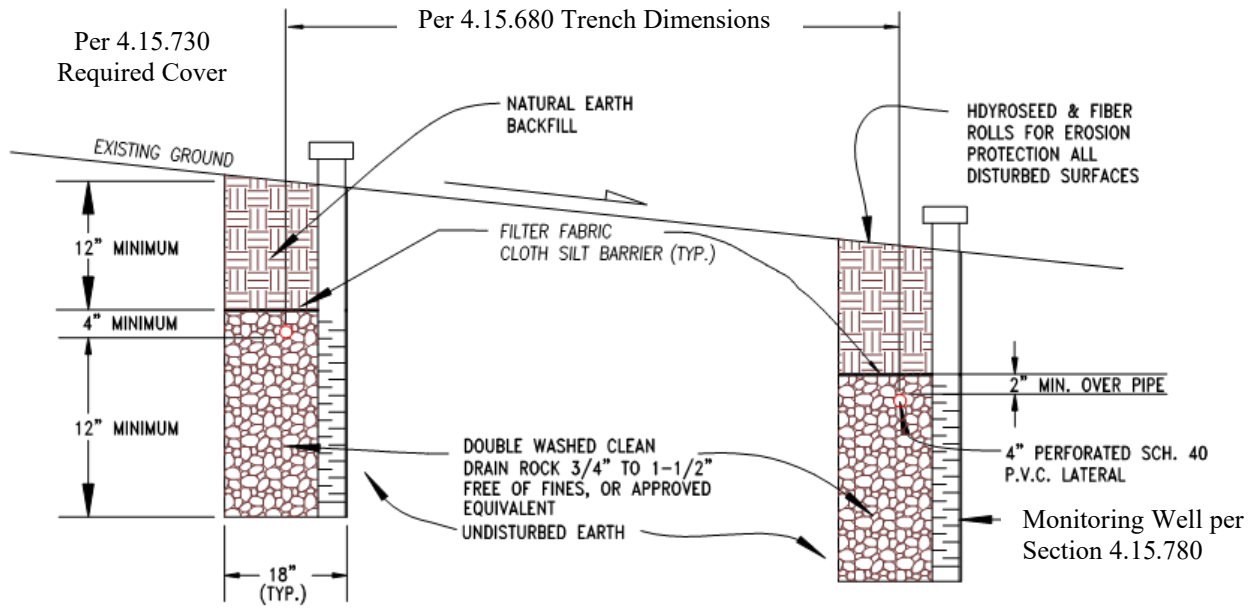

**TYPICAL TRENCH SECTION**

**4.15.700 Effective Wall Trench**

The effective wall trench section is the area measured from below the perforated lateral to the bottom of the trench.

**4.15.705 Chambers**

The effective infiltrative surface shall be considered to be the trench sidewall area between the top of louvered sidewall and trench bottom.

**4.15.710 Trench Tolerance**

Trenches for dispersal fields are to be laid along contours with a tolerance of no greater than three inch deviation in 100 feet of trench bottom.

**4.15.720 Trench Width**

Trenches shall be 18 to 36 inches in width for pressure dosed distribution and serial distribution system.

**4.15.730 Required Cover**

Cover requirements vary based on the slope of the dispersal field. The cover slope requirements from the ground surface to the top of drain rock shall be as follows:

Leach Field Slope (%)	Cover Requirements for Gravity System		Cover Requirements for Pressure Dosed Systems	
	1 - 120 MPI		1 - 30 MPI	31 - 120 MPI
0-10	12"		12"	12"
11-15	18"		12"	12"
16-20	24"		12"	12"
21-30	30"		15"	18"
31-40	n/a		18"	24"
> 40	n/a		24"	30"

#### **4.15.740 Pumps or Dosing Siphons**

If a pump or dosing siphon is utilized to pressurize a dispersal field, the pump or siphon shall be compatible for use with sewage.

#### **4.15.750 Sump/Pump Tanks**

All sump/pump tanks shall meet the following conditions:

1. An external pump basin as per section 4.15.310 shall be installed which shall provide emergency storage for at least 100% of the maximum daily design flow and which shall be accessible for inspection.
2. Access shall be provided by a minimum 24-inch access hole.
3. All pipes and/or electrical conduits through the sump shall be either precast into the sump or sealed with gas-tight compression connectors.
4. All maintenance covers shall be removable, shall be gas and water tight, and shall weigh less than 25 pounds.
5. The following electrical features shall be provided:
  - a. An outdoor-type control box containing fused disconnects and motor protection switch.
  - b. A control box shall be mounted on the building served if located within 20 feet of the sump, otherwise the control box shall be mounted on a pipe stand or wooden post. The control box shall be visible to the road way or as approved by the District Engineer.
  - c. Electrical conduit shall be PVC. Separate conduits shall be provided for control wire and power supply.
  - d. The pumping system shall be installed with a 1/8" screen in the basin.
  - e. Controls shall be of an approved type and shall include approved elapsed time meters and dose counters; an alarm system of an approved type shall be installed to provide a visual and audible warning that effluent in the basin is in the capacity reserved for emergency storage.
  - f. A hands off automatic function.
  - g. The panel shall coordinate mechanical floats for on-off and alarm conditions.
  - h. The bottom of the pump shall be set a minimum of four inches above the sump bottom.
  - i. Aside from the construction permit, the owner shall be responsible for additional permit(s) required by the Marin County Building Division for all pump installations.

#### **4.15.760 Hydraulic Design for Pressure Distribution Systems**

All pressure distribution type systems will have either a pump or a dosing siphon to regulate the size of discreet doses. The dose size should be adequate to insure that the dispersal field will pressurize but as small as possible in order to provide small and frequent dosing of the fields. Where topography will allow gravity flow from the septic tank to the dispersal field, a dosing siphon may be utilized provided a method of counting the doses and an audio/visual alarm is included in the control panel. The pump shall be of the size and type to accommodate the intended use.

#### **4.15.770 Diversion Valve**

All dual dispersal field systems shall be provided with a pressure-rated PVC diversion valve. The valve shall be housed in a box that terminates above grade and is accessible for inspection.

#### **4.15.780 Monitoring Wells**

All trench systems are required to have two monitoring wells, at the ends of the trench, installed to

the depth of the trench. Monitoring wells shall include a 12 inch deep seal of concrete or bentonite to preclude surface water infiltration to the trench. The monitoring well shall have slotted or drilled holes within the effective sidewall area.

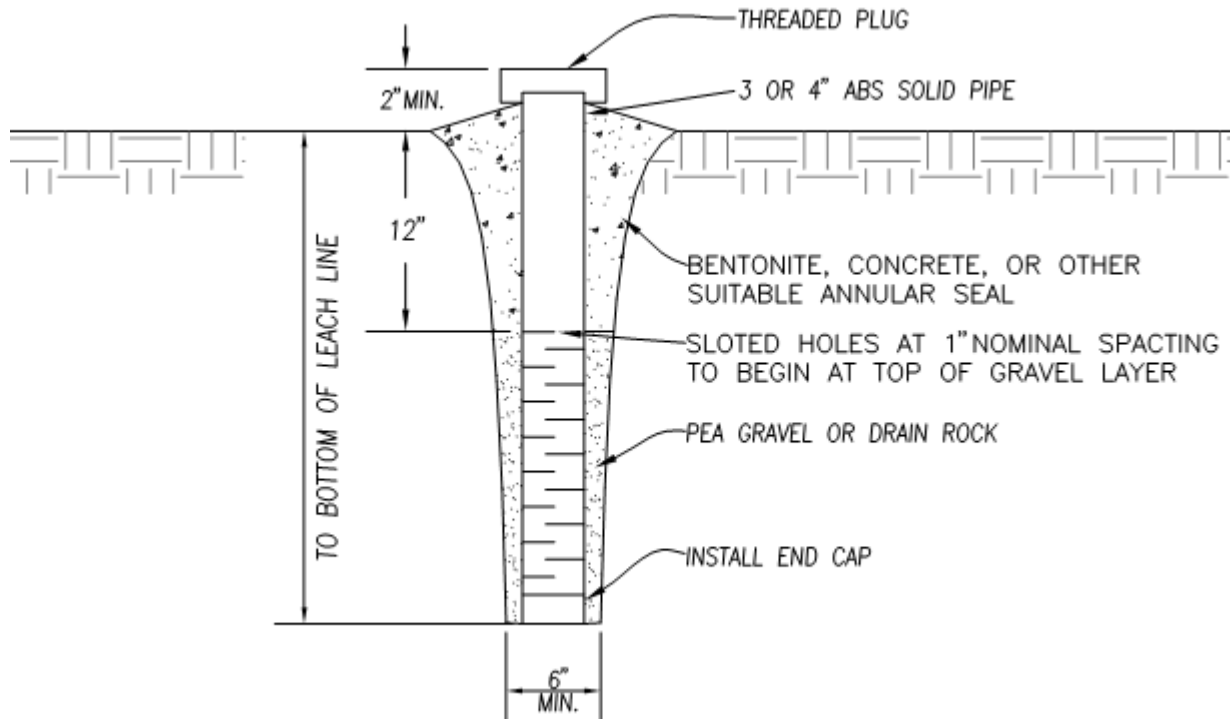

**TYPICAL MONITORING WELL DETAIL**

**4.15.790 Piping**

All pipe throughout the septic system should be schedule 40 or better, sized to accommodate the flows anticipated.

**4.15.800 Pressure Piping**

The pipe from the sump to the dispersal field shall be solid plastic, schedule 40, and sized to meet pumping and effluent flow requirements while minimizing frictional losses. Starting at the pump installation, a union, a swing check valve, and a double wedge gate valve shall be mounted. These items are required either in the sump or adjacent to the sump or in a concrete box.

**4.15.810 Thrust Blocks**

Concrete thrust blocks are required at all bends greater than 45 degrees.

**4.15.820 Gravel**

The gravel utilized in the dispersal field trenches shall be clean (free of fines) and durable sized from 1/4" to 1 1/2".

**4.15.830 Filter Fabric**

Filter fabric is required between the gravel and cover in the leach lines to reduce the migration of fines into the gravel of the trenches.

#### **4.15.900 Use of Intermittent Sand Filters**

A wastewater treatment system using an intermittent sand filter may be used for new construction.

#### **4.15.910 Site Criteria**

Site criteria for all intermittent sand filter systems designs, whether for new construction or for replacement of an existing system, shall be the same as the site criteria for standard systems, except as follows:

1. The measured depth to groundwater shall be at least 24 inches below the existing grade (to achieve the 3 foot depth-to-groundwater requirement a raised-bed leach field may be used).
2. For new construction the soils shall be homogeneous sand.
3. Setback requirements for sand filter system components shall be as specified in Section 4.15.100. Sand filters shall have the same setbacks as septic tanks except as follows:
  - a. Building to leach field: 5 feet
  - b. Adjoining property line to leach field: 5 feet
  - c. Driveways, parking areas, or paved areas to leach field: 1 foot with approved barrier

#### **4.15.930 Leach Field Sizing for Intermittent Sand Filter Systems**

Leach fields shall be sized based on the minimum soil loading rate shown on the table below. This table gives the relationship for average percolation rate of six or more holes and the design loading rates.

Leach Field Requirements For Intermittent Sand Filter Systems,

Percolation Rate (MPI)	Leach Field Design	Design Loading Rate (gpd/ft <sup>2</sup> /day)	Minimum Soil Depth <sup>1</sup> (ft)
< 5	Serial Distribution or Pressure Dose Distribution (PD)	2.4	3
	Raised Bed	1.4	2
5 to 90	Serial Distribution or PD	2.0 x DLR <sup>2</sup>	3
91 to 120	Serial Distribution or PD	0.3	3

<sup>1</sup>Minimum depth of suitable, native soil depth below the bottom of drain field rock

<sup>2</sup>DLR = design loading rate per Section 4.15.670

#### **4.15.940 Intermittent Sand Filter Design Standards**

Intermittent sand filters shall be designed based upon the following standards:

1. The design shall be based upon a design loading rate of 1.23 gallons per square foot per day.
2. Depth of cover shall not exceed 12 inches.
3. Filter fabric shall be of an approved type and design.
4. Distribution bed gravel shall be double-washed pea gravel free of fines; the distribution bed below the piping shall be at least 4 inches deep.
5. The distribution bed piping shall be Schedule 40 PVC sized so that there is

no more than a 2% differential in discharge head with head loss calculations based upon an approved method presented with the design submittals; the pipe shall be laid flat with orifices pointing upward and shall be pressure tested to ensure the integrity of all joints; the orifice shall be 1/8"; orifice shields shall be provided. To provide for more effective utilization of sand bed, orifices shall be spaced on average so that there is four square feet of bed per orifice. An approved valve may be provided to alternately dose at least two sections of the bed. Orifices shall be pre-drilled on a drill press or other approved alternative.

6. The filter bed sand shall be a minimum of two feet deep and the sand shall meet the following criteria:

<u>Sieve Size</u>	<u>Percent Passing</u>
# 4	100
# 8	70-90
# 16	40-60
# 30	25-35
# 50	2-5
# 60	0

D<sub>10</sub>>0.400mm  
D<sub>60</sub>=1.4mm  
U<sub>c</sub> =3.0-4.0

The sand shall be analyzed by wet-sieve analysis using ASTM method C-117 or equivalent. Prior to placement of sand, the District shall be provided with a certified copy of the conforming sieve analysis.

7. The pea gravel in the gravel bed shall be clean, double-washed, and free of fines and at least 6" deep.
8. The under drain shall be 4" PVC pipe of an approved type slotted in an approved manner with slots of 1/8" to 1/16" width, 1/4" on center.
9. The PVC liner shall be 30 millimeter, completely sealed, and free of tears and holes.

**4.15.950 Intermittent Sand Filter Design Flow**

Regardless of the size of the system, the peak flow rate shall conform to requirements listed in Section 4.15.621 for size of the structure.

**4.15.960 Leach Field Design - General**

Leach fields for sand filter systems shall meet the requirements for standard systems listed in Chapter 4.15 and the adjusted design loading rates listed in Section 4.15.930.

**4.15.970 Raised-Bed Leach Field Design**

A pressure distribution raised-bed leach field design may be used to obtain the required depth-to-groundwater in a system which uses an intermittent sand filter or District approved equivalent pretreatment device. A raised-bed leach field design shall, at a minimum, include the following:

1. A PVC pressure-rated diversion valve for alternative between the leach fields (The diversion valve shall be installed within an access box to grade, which is accessible for inspection)



2. An impermeable 30 mil liner shall be installed along the sides of all retaining wall structures.
3. Distribution Bed
  - a. The distribution bed shall consist of 3/8-inch pea gravel, free of fines. The pea gravel shall extend a minimum of 6-inches below the invert and 2-inches above the top of distribution lateral.
  - b. The bottom of the distribution bed shall be level; and the downslope side shall be parallel to the slope contour.
  - c. The gravel distribution bed shall be covered in its entirety with a geotextile ("filter fabric") silt barrier. Filter fabric shall be either polyester, nylon or polypropylene, or any combination thereof, and shall be suitable for underdrain application. Filter fabric shall be non-woven, shall not act as a wicking agent and shall be permeable.
  - d. The soil cover shall be placed over the entire distribution bed. The soil shall consist of medium, loamy-textured soil. The soil cover depth shall be a minimum of 12-inches and a maximum of 18-inches over the top of the distribution bed.
  - e. The design loading rate used for sizing the surface area of the distribution bed shall be 1.4 gal/ft<sup>2</sup>/day.
4. Up to 12 inches of imported soil may be utilized to meet the three feet of vertical separation per Section 4.15.111 Depth to Groundwater. The sand shall meet the sieve size criteria specified in Section 4.15.940 Intermittent Sand Filter Design Standards.

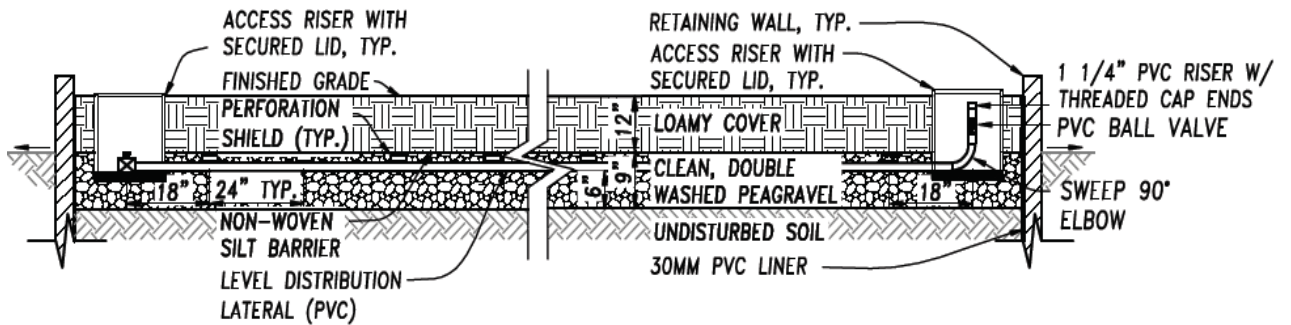

**TYPICAL RAISED BED- SECTION VIEW**

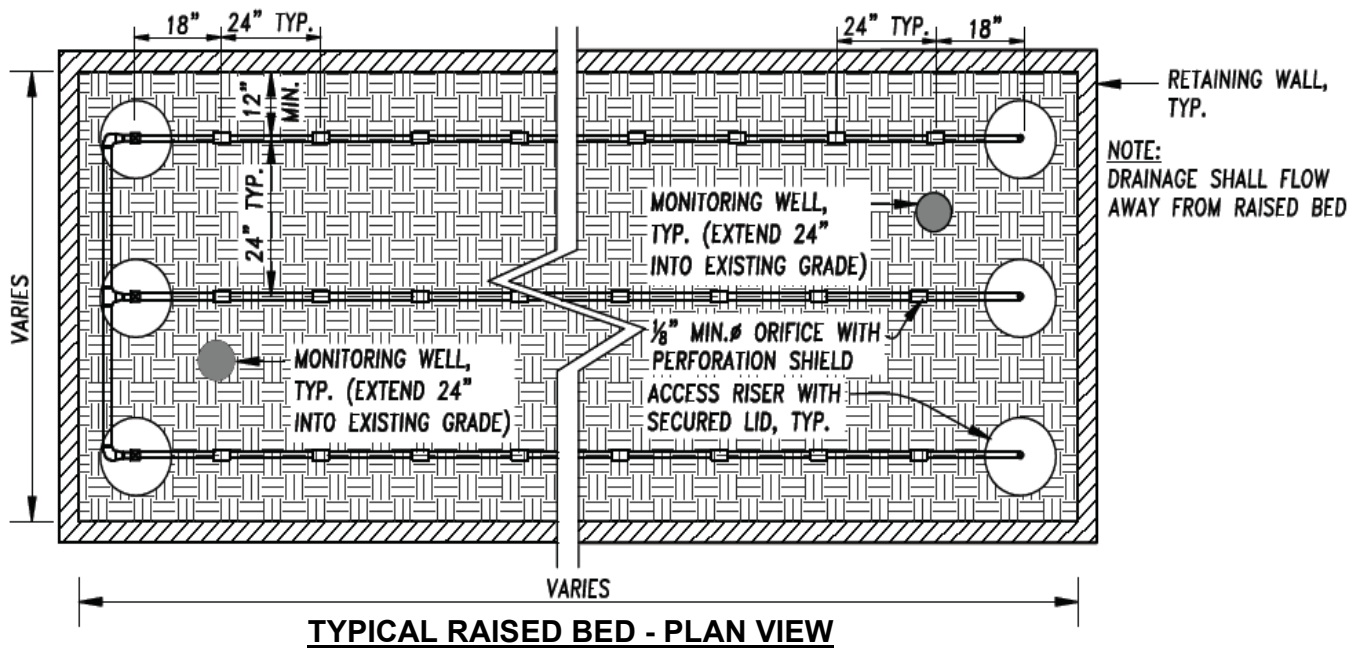

**4.15.980 Maintenance Program and Maintenance Design Features**

The application submitted pursuant to Section 4.07.110 for a sand filter system shall include a maintenance program and maintenance design features.

**4.15.990 Maintenance Design Features**

The designer may include such maintenance design features as may be considered appropriate, but shall include:

1. A means for evaluating the residual head at the terminal orifice of each lateral of the distribution bed piping.
2. A means for flushing each lateral to remove material blocking or which may block the orifices.

**4.15.995 Maintenance Program**

The maintenance program shall provide for such maintenance recommendations as the designer may deem necessary, and may include:

1. A recommended frequency and procedure for flushing and cleaning laterals and determining that the residual orifice head is within design specification.
2. A chart for recording pump readings, annual evaluations, and septic tank pumping records to be submitted to the District at the time of the regular inspection of the system.
3. A signed contract from a contractor properly licensed to maintain systems to provide recommended maintenance for a period of not less than two years.
4. Planting and irrigation practices for over and near the sand filter and dispersal field.
5. Proper practices for disposing of household wastes within the system.
6. Proper practices for operation of the system, including flow rates, diversion valve operation, alarm operation, etc.

## Chapter 4.19: DESIGN: ALTERNATIVE WASTEWATER SYSTEMS

### **Sections:**

4.19.010	Use of Alternative Wastewater System Designs
4.19.020	Use of Alternative System Design – Repair or Replacement of Failed System – Granting of Variance
4.19.030	Use of Alternative System Design - Replacement of Failed System in Cases of Fire or Disaster – Granting of Variance
4.19.040	Use of Blowers
4.19.045	Grease Traps
4.19.050	Residential Systems – High Volume
4.19.100	Site Evaluation
4.19.110	Use of Drip Dispersal Fields
4.19.120	Site Criteria for Drip Dispersal
4.19.140	Septic and Sump Tank Design Standards
4.19.150	Drip Irrigation/Drip Dispersal Field Design Standards
4.19.160	Drip Irrigation – Installation and Cover
4.19.170	Material-Dripline
4.19.180	Filters
4.19.190	Ultra Violet Disinfection Systems
4.19.200	Pretreatment Device
4.19.210	Telemetry Control Panel
4.19.220	Drip System Maintenance

### **4.19.010 Use of Alternative Wastewater System Designs**

Alternative wastewater system designs may not be used, unless approved through Variance by the Board of Directors of the Stinson Beach County Water District and the San Francisco Regional Water Quality Control Board.

### **4.19.020 Use of an Alternative System Design - Repair or Replacement of Failed System – Granting of Variance**

The District has determined that alternative treatment system technological improvements have increased performance in monitoring, operation, and process, and that a variance may be granted for installation of an alternative system which is approved by the National Sanitation Foundation in place of a standard onsite septic system for repair or replacement of failed systems.

### **4.19.030 Use of Alternative System Design - Replacement of Failed System in Cases of Fire or Disaster – Granting of Variance**

Except as otherwise provided within this code, where a residence has been totally or partially destroyed by fire, flood, or other natural disaster, and it has been shown to the satisfaction of the District Manager and the District Engineer that a septic system which complies with this code cannot be constructed upon the property, a variance may be granted for installation of an alternative system as defined in Section 4.03.202, under the following conditions:

1. The application for a variance is made within five years of the destruction of the residence; and

2. The replacement structure is within the same footprint as the destroyed residence; and/or
3. The replacement structure does not contain greater square footage than the destroyed structure (if replacement structure exceeds original square footage a variance is required).

**4.19.040 Use of Blowers**

Setback requirements for blowers shall be 10 feet to adjoining property line.

**4.19.045 Grease Traps**

Grease Traps (UPC Listed) are required for commercial facilities that have the potential to produce grease-laden wastewater as determined by the District. Small Bed and Breakfast facilities may be exempt from commercial requirements at the discretion of the District. The following is required when it is determined that grease traps are required:

1. Plans and specifications for the plumbing system including the grease trap shall be submitted to the District.
2. Wastewater from dishwasher sinks and other plumbing fixtures shall be plumbed separately from other plumbing fixtures into the grease trap and then to the septic tank.
3. Grease traps shall be located, installed, and constructed so that temperature of the waste shall be reduced to permit separation of grease and allow easy access for cleaning.
4. Commercial facilities generating 200 gallons or more per day of waste shall install a grease trap sized in accordance with the following formula:

Size of grease trap (in gal) = (S)x(WW)x(ST)x(H)x(LF) where:

S = Number of seats in dining area

WW = Wastewater per meal in gallons (5 gals is normal)

ST = Storage Capacity factor (2.5 is used for wastewater systems)

H = Number of hours in operation of the facility

LF = Loading Factor (a standard of 1.25 is used)

5. Grease traps shall be maintained in efficient operating condition by periodic removal of the accumulated grease. No such collected grease shall be introduced into any drainage piping or septic system.

**4.19.050 Residential Systems – High Volume**

Any onsite wastewater system design intended to serve wastewater design flows in excess of 600 gallons per day or average daily flows in excess of 400 gallons per day shall be considered a high volume residential system. A high volume residential system shall be considered an alternative system and may be approved only through the granting of a variance.

**4.19.100 Site Evaluation**

Site evaluation requirements shall be the same as for standard systems.

**4.19.110 Use of Drip Dispersal Fields**

Drip dispersal fields may be used when the site meets all standard wastewater system design requirements or as a repair/replacement option where standard repair options can be met.

**4.19.120 Site Criteria for Drip Dispersal**

In order to utilize a drip dispersal system for new construction, a preliminary plan with calculations demonstrating that the site could meet the regulations for a standard type system

shall be provided. The preliminary plan shall include a site plan showing all the major system items, property boundaries, setbacks, and site topography. Site setbacks, slope requirements and soil requirements shall be the same as other types of dispersal fields.

**4.19.140 Septic and Sump Tank Design Standards**

Septic and sump tank standards shall be the same as for standard systems.

**4.19.150 Drip Irrigation/Drip Dispersal Field Design Standards**

The following design loading rates assume a treated effluent with Biological Oxygen Demand (BOD) and Total Suspended Solids (TSS) per the drip tubing manufacturer’s requirements.

Soil Class	Soil Type	Est per rate (min/in)	Hydraulic conductivity (in/hr)	Design loading rate (gal/ft2)
I	Coarse sand	<5	>2	1.400
I	Fine sand	5-10	1.5-2	1.200
II	Sandy loam	10-20	1.0-1.5	1.000
II	Loam	20-30	0.75-1.0	0.700
III	Clay loam	30-45	0.5-0.75	0.600
III	Silt-clay loam	45-60	0.3-0.5	0.400
IV	Clay no swell	60-90	0.2-0.3	0.200
IV	Clay swell	90-120	0.1-0.2	0.100
IV	Poor clay	<120	<0.1	0.075

The required dispersal area shall be based on the peak flow rate and design loading rate. The design shall identify an area capable of 300% of the design daily flow.

The design shall utilize two dispersal areas sized for 100% of the design flow and further identify an area capable of 100% of the design flow reserved for future use, for a total of 300% of the design requirement.

All drip systems shall require treated effluent from a pretreatment device prior to dispersal. The National Sanitation Foundation (NSF) shall approve all treatment system options.

**4.19.160 Drip Irrigation – Installation and Cover**

Drip irrigation shall be installed through the use of a plough type installation tool or by hand excavation. The dripline shall have a minimum cover of six inches and shall be installed in native material. Open trench excavation is permitted for the solid pipe connections and for valve installation.

**4.19.170 Material-Dripline**

Dripline Material shall be flexible ½” polyethylene dripline with in-line emitters. The emitters shall be part of the dripline and have flow rates to meet the application rate required. The drip line shall have a bactericide protection impregnated as part of the manufacturing process to prevent bacteria forming; additionally the dripline shall inhibit roots from clogging the emitters with herbicide and bactericide emitters. The dripline shall have fittings on the ends to allow connection to standard schedule 40 pipe, or alternatively non-emitting pipe to match the dripline.

#### **4.19.180 Filters**

A filter shall be placed between the pump and drip lines to keep debris out of the drip fields. The filter shall attach to a dripline between dispersal field and pump and shall be manufactured from a corrosion resistant material and shall be watertight. The filter be manufactured from stainless steel and shall be 100 micron, 150-mesh filter. The filter shall be self-cleaning during the flush cycles. Filter types shall be subject to approval by the District Engineer.

#### **4.19.190 Ultra Violet Disinfection Systems**

Where groundwater is observed within 48-inches from the bottom of the dispersal field, an ultra-violet light disinfection (UV) system shall be required. The UV shall be source mounted on a subassembly, which can be removed and reinstalled through the top of the riser for easy service. The UV light will operate continuously whether or not water is flowing in the disinfection chamber. The alarm relay circuit shall be connected to an external audible alarm and to a control panel telemetry module relayed to the District to warn of possible failure.

#### **4.19.200 Pretreatment Device**

All drip systems shall require treated effluent from a pretreatment device prior to dispersal. The National Sanitation Foundation (NSF) shall approve all treatment system options.

#### **4.19.210 Telemetry Control Panel**

All drip systems shall have a telemetry control panel with proper modules or remote readings as approved by the District. The panel shall have a phone line connection. Panel system parameters shall have remote operation access and the ability to be adjusted on site. The panel location shall be approved by District staff at an easily accessed outside location. The panel shall control the pump cycles based on programmed dosing, activate the solenoid valves to discharge each field, record pump(s) counts, record pump(s) elapsed time, and automatically flush the drip field and filter. The panel shall provide alarms for high water in the various pump chambers and failure of the pretreatment system. Alarms shall be located at the panel utilizing the system. The alarm shall be a minimum of 80 dB and shall be recorded in the digital memory of the control panel.

#### **4.19.220 Drip System Maintenance**

Required maintenance of a drip system shall include periodic monitoring and review of the system condition and parameters via remote telemetry.

## Chapter 4.23: DESIGN: HOLDING TANKS AND GRAYWATER SYSTEMS

### **Sections:**

<b>4.23.100</b>	<b>Use of Holding Tanks</b>
<b>4.23.110</b>	<b>Holding Tank Compliance</b>
<b>4.23.120</b>	<b>Holding Tank Design Standards</b>
<b>4.23.200</b>	<b>Graywater Systems</b>
<b>4.23.210</b>	<b>Application for Graywater System Construction Permit</b>
<b>4.23.220</b>	<b>Graywater Tank Design</b>
<b>4.23.230</b>	<b>Connections to Graywater Tank</b>
<b>4.23.240</b>	<b>Graywater Irrigation and Dispersal Field</b>
<b>4.23.250</b>	<b>Graywater Discharge</b>
<b>4.23.260</b>	<b>Clothes Washer System</b>
<b>4.23.300</b>	<b>Simple System</b>
<b>4.23.360</b>	<b>Complex System</b>

### **4.23.100 Use of Holding Tanks**

No person shall use any temporary or permanent tank for holding wastewater for later disposal off site, such as a holding tank, except:

1. In connection with the repair of a failed wastewater treatment system; or,
2. In the case of a failed system replacement, where the District has determined that all other options for a replacement system have been considered by the applicant and that a holding tank is the only remaining feasible option.

### **4.23.110 Holding Tank Compliance**

All holding tanks shall comply with the following:

1. Issuance of a permit and payment of prescribed holding tank fees. The holding tank permit fee may be periodically collected and may be charged on a unified water service bill.
2. Periodic submittal of documents verifying that the required pumping has been completed by a person licensed by the County of Marin pursuant to Section 25000 et seq. of the Health and Safety Code.
3. Installation of an audio/visual alarm within 20 feet of the holding tank; to be activated when the tank is within 85% of total capacity.

### **4.23.120 Holding Tank Design Standards**

All tanks shall meet all of the following design standards:

1. The tank shall have a minimum 1,200 gallon capacity.
2. The tank shall be NSF approved and constructed of solid, durable materials not subjected to excessive corrosion or decay and shall be watertight. The tank shall be vented as required in Chapter 9 of the California Building Code.
3. The tank shall be constructed of either concrete or fiberglass.
4. Unless approved by the District, fiberglass tanks shall not be installed within the Special Flood Hazard Area. Approval of the fiberglass tanks may be granted on case by case basis due to limited or no access to the tank location.

5. Tanks shall be installed such that access ports or openings are at least twelve inches below grade with at least one (1) riser which reach two (2) inches minimum above the ground surface.
6. Tanks shall be installed level on a solid bed and in no case shall the depth be greater than the manufactures limits of cover. Soil around the tank shall be hard-compacted or jetted.

**4.23.200 Graywater Systems**

Any onsite wastewater system design which conforms to 2013 California Plumbing Code (CPC), Chapter 16, Non-potable Water Reuse Systems, shall be designated a graywater system. And further described as a system designed to collect graywater and transport it out of the structure for distribution in an irrigation or dispersal field. A graywater system may include tanks, valves, filters, pumps, or other appurtenances along with piping and receiving landscape.

The following requirements apply to all graywater systems:

1. Installation of graywater systems shall, at a minimum conform to 2007 CPC, Title 24, Part 5, Chapter 16A, Part I – Nonpotable Water Reuse Systems.
2. Graywater use indoors is prohibited.
3. Graywater will not be used to irrigate root crops or edible part of food crops that touch the soil.
4. Graywater will not be used for spray irrigation.
5. Graywater will not be allowed to pond or runoff.
6. Graywater will not be discharged directly into any drainage swale, storm drain system, or surface water body.
7. Water used to wash diapers or similarly soiled or infectious garments will not be used in the graywater system.
8. Water used to wash oily rags or to dispose of hazardous waste solutions such as from home photo labs will not be used in the graywater system.
9. Graywater includes but is not limited to wastewater from bathtubs, showers, bathroom washbasins, clothes washing machines, and laundry tubs, but does not include wastewater from kitchen sinks or dishwashers.
10. Periodic inspections no less than every two (2) years shall be conducted by District staff. Inspection frequency will coincide with the wastewater system inspection for the subject property. Section 4.07.725 Accessibility for Periodic Inspections shall be applicable.
11. The graywater system shall not be connected to any potable water system without an air gap or other physical device which prevents backflow. A backflow device (RPP type approved by District staff) shall be required to protect potable water from contamination.
12. An operation and maintenance manual shall be provided and maintained through the life of the system and upon change of ownership or occupancy. A copy of this manual shall be provided to the District.
13. Installation of a water system backflow prevention device (RPP Type) approved by the District.

**4.23.210 Application for Graywater System Construction Permit**

To obtain a Graywater System Construction Permit, the owner or designated agent of the property on which the proposed work is to be conducted shall complete the application form and pay the prescribed permit fee. The application shall:

1. Identify and describe the work to be covered by the permit;



2. Provide the street address and Marin County Assessor's Parcel Number
3. Provide the Owner and Design contact information
4. Provide at least one (1) soil profile log, as described in Section 4.15.221, in the vicinity of the graywater dispersal field
5. Provide three (3) sets of plans, diagrams, computations, specifications, and other data for construction of the graywater system. If plans are larger than 11" x 17", then one (1) reduced 11" x 17" plan set shall be provided in addition to the three (3) sets of plans.
6. Give such other data and information as may be required by the General Manager.

#### **4.23.220 Graywater Tank Design**

When system design includes a tank, specifications for the tank shall be submitted to the District for approval. All graywater tanks shall meet the following:

1. Tanks shall be NSF approved and constructed of solid, durable materials not subject to excessive corrosion or decay and shall be water-tight. Steel tanks are prohibited.
2. Each tank shall have an access opening to allow for inspection and cleaning. All maintenance covers shall be removable and shall be gas and watertight. Unless approved by the District Engineer for use with a traffic rated tank, tank lids shall not weigh more than 25 pounds and must be securely fastened to access risers of an approved type.
3. Tanks shall be vented as required by Chapter 9 of the California Plumbing Code. The tanks shall be sealed against vermin and mosquitoes.
4. Tanks shall have its rated capacity permanently marked on the unit with a sign stating "Graywater Irrigation System, Caution – Unsafe Water" permanently marked in a visible location on the tank lids.
5. An overflow drain shall be designed to allow overflow to gravity flow into the inlet side of the septic tank. The overflow drain shall not be less than the inlet pipe. The tank shall be protect against sewer line backflow by a backwater valve.
6. Tanks shall be designed to minimize detention time and sized to distribute the estimate amount of graywater produced on a daily basis.
7. Setback requirements shall adhere to Section 4.15.100

#### **4.23.230 Connections to Graywater Tank**

All pipe, valves, fittings, and connections to a septic tank shall be made in a manner consistent with the Uniform Plumbing Code Section 1610 A.1, 2, 3.

#### **4.23.240 Graywater Irrigation and Dispersal Field**

There shall be sufficient area and appropriate soil condition on the parcel to prevent ponding or runoff of graywater. The graywater irrigation and dispersal field shall meet the following:

1. The type of irrigation and dispersal field shall be determined by the location, discharge capacity, soil type, and ground water level. Graywater discharge from irrigation or disposal field systems shall be at least two (2) inches deep to minimize the possibility of human contact.
2. Setback requirements shall adhere to Section 4.15.100
3. No graywater system shall be permitted if areas where the absorption capacity of the soil is unable to accommodate the intended discharge of the proposed dispersal field.
4. No irrigation and dispersal field shall extend within three (3) vertical feet of the highest know groundwater elevation or to a depth where graywater contaminates the ground water, ocean water, or surface water.

#### **4.23.250 Graywater Discharge**

The graywater discharge shall be calculated by estimates on water use records and the following:

Estimate the number of occupants of each dwelling unit as follows:

First Bedroom	2 occupants
Each Additional Bedroom	1 occupant

Estimate graywater flows based on number of occupants as follows:

Showers, bathtubs & wash basins	25 GPD/occupant
Laundry	15 GPD/occupant

The total number of occupants shall be multiplied by the applicable estimated graywater discharge as provided above and the type of fixtures connected to the graywater system.

#### **4.23.260 Clothes Washer System**

A clothes system utilizes only a single domestic clothes washing machine in a single family residential dwelling. The system design shall include the following:

1. Ability of the user to direct flow with a diversion valve to the irrigation / dispersal field or to the inlet side of the septic tank. The direction control of the graywater shall be clearly labeled and readily accessible to the user.
2. Installation of an air vent at the high point of the supply manifold
3. Release of graywater above the ground surface provided at least two (2) inches of mulch, rock, or soil, or a solid shield covers the release points. Other methods which provide equivalent separation are also acceptable.
4. Minimize human and domestic pet contact with the graywater system
5. A construction inspection schedule to observe, at a minimum, the following:
  - Prior to construction, the layout of the irrigation or dispersal field
  - Operation of diversion valve
  - A flow test to the point of the graywater irrigation or dispersal field to show lines and components are watertight

#### **4.23.300 Simple System**

Simple systems exceed a clothes washer system and comply with the following:

1. The discharge capacity shall be 250 gallons per day or less.
2. Graywater systems with a tank shall have an overflow system such that the tank overflow will gravity flow to the inlet side of the septic tank.
3. Excess graywater from the irrigation or dispersal field shall flow to the inlet side of the septic tank through a diversion valve.
4. All construction work done pursuant to a Construction Permit shall be done by, or under the supervision of, a person holding an appropriate license as a contractor pursuant to state law. The owner may be authorized to perform permitted maintenance or repair work of a minor nature which will not endanger the public health, nor violate any laws, ordinances, or regulations.
5. Submittal of a Designer's Observation schedule per Section 4.07.131 to observe work conforms to the approved application, plans, and specifications and shall include, at a minimum, the following:

- Prior to construction, the layout of the irrigation or dispersal field
- Watertight test of tank(s), as applicable
- Operation of diversion valve
- A flow test to the point of the graywater irrigation or dispersal field to show lines and components are watertight

**4.23.360      Complex System**

Any graywater system which is not a clothes washer or simple system shall comply with the following:

1. The discharge capacity is over 250 gallons per day.
2. Design plans shall be prepared by an approved Designer per Section 4.03.212.
3. Site Evaluation per Section 4.15.200 shall be performed by the Designer with observation by District staff.
4. Graywater systems with a tank shall have an overflow system such that the tank overflow will gravity flow to the inlet side of the septic tank.
5. Excess graywater from the irrigation or dispersal field shall flow to the inlet side of the septic tank through a diversion valve.
6. All construction work done pursuant to a Construction Permit shall be done by, or under the supervision of, a person holding an appropriate license as a contractor pursuant to state law. The owner may be authorized to perform permitted maintenance or repair work of a minor nature which work will not endanger the public health, nor violate any laws, ordinances, or regulations.
7. Submittal of a Designer's Observation schedule per Section 4.07.131 to observe work conforms to the approved application, plans, and specifications and shall include , at a minimum, the following:
  - Prior to construction, the layout of the irrigation or dispersal field
  - Watertight test of tank(s), as applicable
  - Operation of diversion valve
  - A flow test to the point of the graywater irrigation or dispersal field to show lines and components are watertight

**Table 16A-1 Location of Graywater Systems**

<b>Minimum Horizontal Distance Required From:</b>	<b>Tank (feet)</b>	<b>Irrigation Field (feet)</b>	<b>Dispersal Field (feet)</b>
Building Structures <sup>1</sup>	5 <sup>2</sup>	2	5
Property Line	5	1.5	5
Water Supply Wells <sup>3</sup>	50	100	100
Streams and Lakes <sup>3</sup>	50	100 <sup>4,5</sup>	100 <sup>4</sup>
Sewage Pits or Cesspools	5	5	5
Sewage Dispersal Field	5	4 <sup>6</sup>	4 <sup>6</sup>
Septic Tank	0	5	5
Domestic Water Line	5	0	0
Public Water Main	10	10 <sup>7</sup>	10 <sup>7</sup>

<sup>1</sup>Building structures do not include porches and steps, whether covered or uncovered, breezeways, roofed porte cocheres, roofed patios, carports, covered walks, covered driveways, and similar structures or appurtenances.

<sup>2</sup>Underground tanks shall not be located within a 45-degree angle from the bottom of the foundation, or they shall be designed to address the surcharge imposed by the structure. The distance may be reduced to six (6) inches for aboveground tanks when first approved by the District.

<sup>3</sup>Where special hazards are involved, the distance required shall be increased as directed by the District.

<sup>4</sup>These minimum clear horizontal distances shall also apply between the irrigation or dispersal field and the ocean mean higher high tide line.

<sup>5</sup>The minimum horizontal distance may be reduced to 50 feet for irrigation fields utilizing graywater which has been filtered prior to entering the distribution piping.

<sup>6</sup>Plus two (2) feet for each additional foot of depth in excess of one (1) foot below the bottom of the drain line.

<sup>7</sup>For parallel construction or crossings, approved by the District shall b

**Table 16A-2 Design Criteria of Six Typical Soils**

<b>Type of Soil</b>	<b>Square Feet Min. ft<sup>2</sup> of irrigation / leaching area per 100 gal of estimate daily graywater discharge</b>	<b>Gallons Max absorption capacity in gal/ft<sup>2</sup> of irrigation / leaching area for 24 hrs</b>
Coarse sand or gravel	20	5
Fine Sand	25	4
Sandy Loam	40	2.5
Sandy Clay	60	1.7
Clay with considerable sand or gravel	90	1.1
Clay with small amounts of sand or gravel	120	0.8

